

LIBERA

SOLUTIONS FOR PARTICLE ACCELERATORS

LIBERA

BOOK'26

LIBERA

SOLUTIONS FOR PARTICLE ACCELERATORS



LIBERA REFERENCES

ASIA

BARC
HIRFL—CSR
HiSOR
HUST
IBS—RISP
IHEP-CAS—BEPC II, ADS, CSNS, HEPS
IMP-CAS—C-ADS, LEAF, SSC-LINAC,
IMS—UVSOR
Inter University Accelerator Centre
ISSP
KAERI—KOMAC
KEK—PF, PF-AR, LINAC, SUPER B,
J-PARC, cERL
Nagoya University—Aichi Synchrotron
NewRT Medical Systems
NSRRC—TLS, TPS
PAL—PLS II, PAL XFEL, EUV, 4GSR, PIEAS
RRCAT—INDUS, INDUS II
SACLA—Spring-8
SAGA
SINAP—SSRF, SXFEL
SJTU
SLRI—SPS
Tsinghua University
USTC—NSRL

AUSTRALIA

ANSTO—Australian Synchrotron

EUROPE

AVO-ADAM—LIGHT
BINP—SKIF
CELLS—ALBA
CERN
CNAO
DESY—DORIS III, European XFEL,
FLASH, PETRA III, PETRA IV
Diamond Light Source
ELI Beamlines
ELI-NP—VEGA
ESRF—ESRF-EBS
Forschungszentrum Jülich—COSY
Fritz Haber Institute

GSI—FAIR
HZB—BESSY II, MLS
HZDR—ELBE
INFN-LNF—Daphne, ELI-NP, SPARC,
Latino, Sabina, CLEAN, STAR
INFN-LNS
INFN-LNL—SPES
Jagiellonian University—SOLARIS
JINR—NICA
KIT—KARA, cSTART
IJCLab—ThomX
Lund University—MAX III, MAX IV
MedAustron
Physics Institute of the University of Bonn
PSI—SLS, SwissFEL
Research Instruments
RRC Kurchatov Institute—SIBERIA II
ScandiNova
SCK-CEN—MYRTE, MINERVA
SESAME
Sincrotrone Trieste—Elettra, Elettra 2.0,
FERMI
Synchrotron SOLEIL—SOLEIL, SOLEIL II
STFC ASTeC—EMMA, CLARA

NORTH AMERICA

ANL—APS, APS-U
Best Medical International
BNL—ERL, NSLS II, X-RAY ring
Bridge 12
Canadian Light Source
Cornell University—CHESS, CESR
Fermilab
LBNL—ALS
NUSANO
Oak Ridge National Laboratory
RadiaBeam
SLAC—LCLS, SPEAR 3
xLight

SOUTH AMERICA

ABTLuS—LNLS

A word from our CEO

Elvis Janežič, CEO of Instrumentation Technologies



“The Libera folks,” that’s how the accelerator community knows us, and we’ve made quite an impression since we began our story back in 2003.

Over the last two decades we have supplied nine out of ten synchrotron light sources around the world with our Libera beam position monitoring and stabilization systems.

We believe Libera is much more than just the sum of its parts. It offers the best possible performance for the price, with proactive engineering, reliability and long-term support. But for us, it is the relationships with our customers that Libera has enabled us to develop over the years that we cherish the most.

Today, Libera addresses a wider range of particle accelerator applications including Beam Loss Monitoring, Digital Low-Level RF controls and RF generation and distribution, offered for both circular and linear machines. This means more tools for our users and also the possibility to enter exciting new application areas, such as Particle Therapy and Isotope production.

In the last few years we have also started to offer our domain knowledge and technical expertise to users that have chosen different HW platforms, and this resulted in the first projects using the standard MTCA.4 boards and in the first industrialization of prototypes developed by the customers.

Going forward, we believe that combining our expertise and the building blocks developed thus far with a flexible, proactive approach and long term support will enable us to partner with the most challenging projects, and to find innovative ways to meet the requirements for the machines of the future.



TABLE OF CONTENTS

Beam Position Monitor Electronics	06	Digital LLRF	27
<i>Hadron BPM Electronics</i>	06	Libera LLRF	27
Libera Hadron	07	Libera TSU	29
Libera Single Pass H	07		
Libera Spark HR	08	Synchronization	30
Libera Spark HL	08	Libera RMO	30
<i>Electron BPM Electronics</i>	10	Libera Distribution Amplifier	32
Libera Brilliance+	10	Libera Sync	33
Libera Brilliance X	11		
Libera 2BPMRTM	11	Architecture and Control System	35
DAMC-UNIZUP	12	Integration	
Libera Spark ERXR / ERPT	13		
Libera Single Pass E	13	Extensions	37
Libera Spark EL	14	Orbit Feedback Solutions	38
Libera CavityBPM	14	DAI Module	38
<i>X-Ray BPM Electronics</i>	17	SER Module	39
Libera Photon	17	SER 2 Module	39
		GDX Module	40
Beam Loss Monitor	18	Libera DWC	40
Libera BLM	18	Libera Amplifier 110	41
Libera BLD	19	Libera BPM AMP	42
		Libera Pilot Tone FE	43
Digitizers	21	Libera XBS FE	44
Libera Digit 125	21		
Libera Digit 500	22	Libera VIVA	45
		Services & Support	
Beam Current Monitor	23	Contact	46
Libera Digit 500	23		
Current Meter	25		
Libera Current Meter	25		

BEAM POSITION MONITOR ELECTRONICS

Libera Beam Position Monitor (BPM) electronics feature a high-resolution position measurement of the beam (electrons, protons, ions, photons, etc.). Their flexible digital signal processing calculates the beam position with different bandwidths and techniques, enabling measurements in different beam modes and regimes.

- pulsed, single bunch
- pulsed, micro/macro pulse
- bunch-by-bunch
- turn-by-turn
- first-turn measurement
- closed loop (fast, slow)

HADRON	ELECTRON	X-RAYS
<ul style="list-style-type: none">• Libera Hadron• Libera Single Pass H• Libera Spark	<ul style="list-style-type: none">• Libera Brilliance+• Libera Single Pass E• Libera Spark• Libera CavityBPM	<ul style="list-style-type: none">• Libera Photon

HADRON

Beam Position Monitor Electronics

Instruments intended for use in Hadron machines are shown in Figure 1. Several versions are available, based on different technology and form factors. They provide various levels of measurement performance and functionalities. The BPM pickup types supported are button and shoebox pickups.

Figure 1: Example of hadron machine: LINAC injector, transfer line, synchrotron, and extraction line

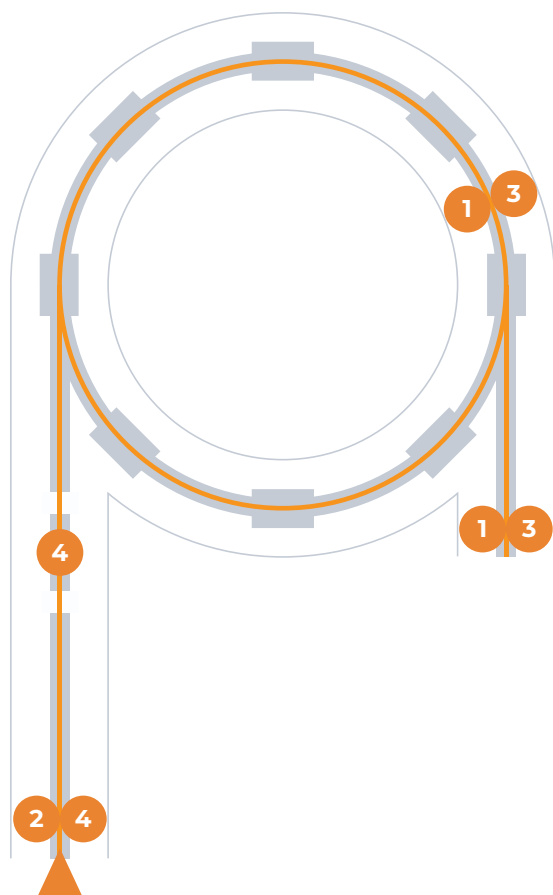

1 Libera Hadron

Used in proton/hadron synchrotrons



More

Libera Hadron is a beam position processor. It can perform beam position measurements, tune measurement, FFT processing, FFT peak calculation, slow position monitoring, etc. The modular platform hosts up to four BPM modules, a timing module and optionally a Gigabit Data Exchange (GDx) module for Orbit Feedback solution or real-time data streaming.

Accessories: Libera Amplifier 110.

Extensions: Real-time data streaming, feedback application, serial I/O interface.

Figure 2: Libera Hadron front panel (block diagram)

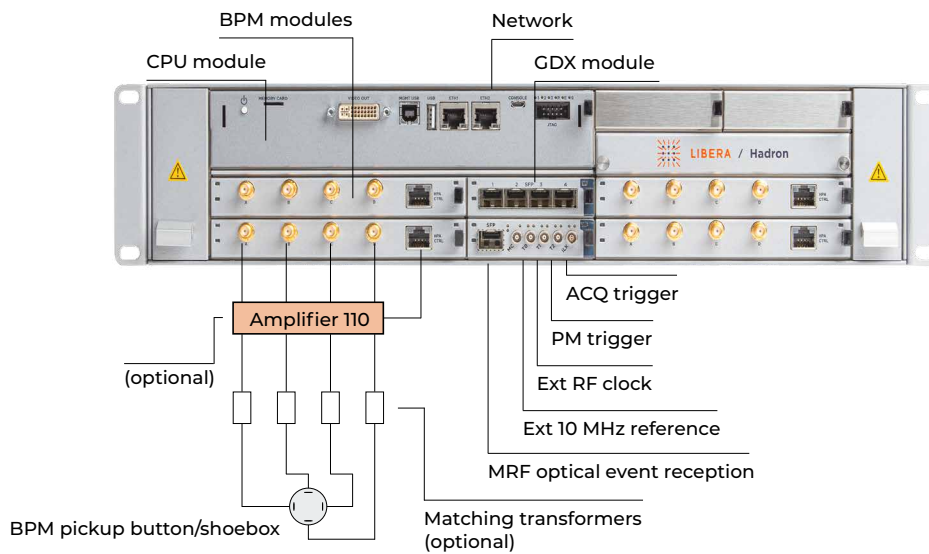

2 Libera Single Pass H

Used in proton/hadron linear accelerators



More

Libera Single Pass H is a beam position and phase processor. It can perform beam position and phase measurements for two signal harmonics simultaneously. The modular platform hosts up to four BPM modules, a timing module and optionally a Gigabit Data Exchange (GDx) module for real-time data streaming.

Extensions: Real-time data streaming, feedback application, serial I/O interface.

Figure 3: Libera Single Pass H front panel (block diagram)

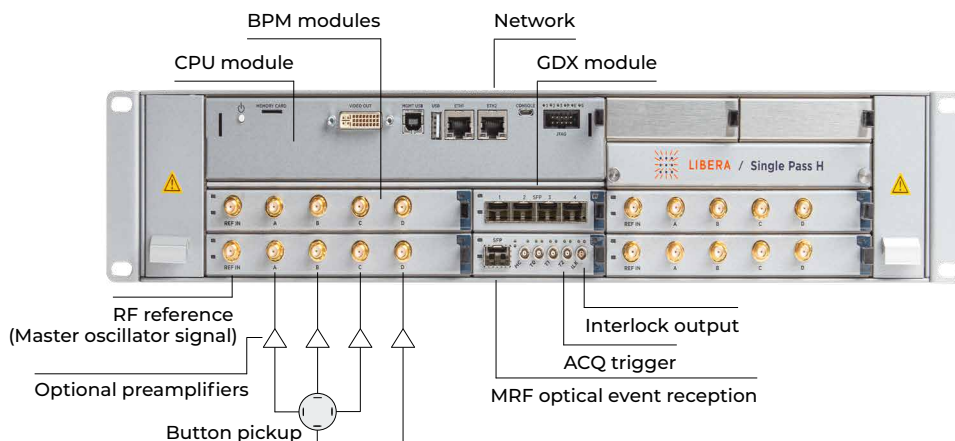

3 Libera Spark HR

Used in proton/hadron synchrotrons and ring-to-target beam transfers



More

Libera Spark HR is a beam position processor that supports the readout from a single BPM pickup and enables bunch-by-bunch data processing. The instrument can output a real-time data stream and can be integrated with the machine protection system (Interlock detection).

Extensions: Interlock output, real-time data streaming, analog output, digital (serial) I/O.

Figure 4: Libera Spark HR front and back panel (block diagram)

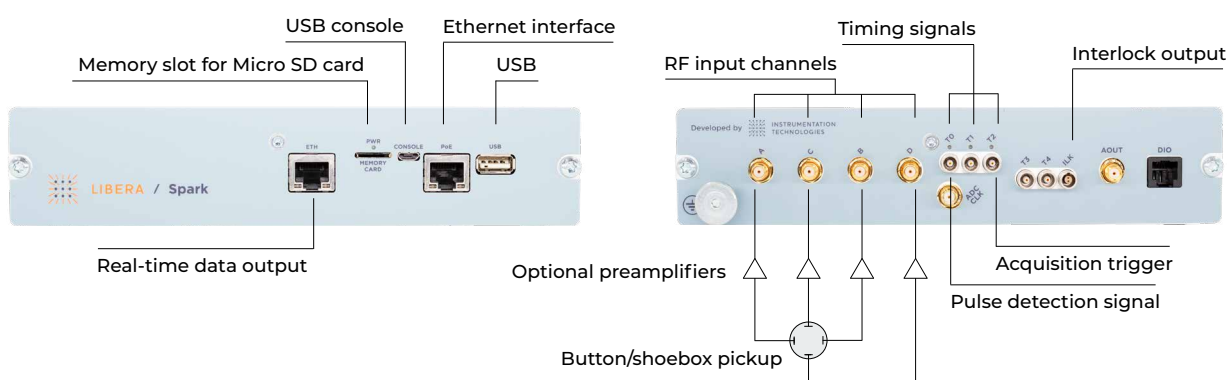

4 Libera Spark HL

Used in proton/hadron linear accelerators and transfer lines



More

Libera Spark HL is a beam position processor that supports the readout from a single BPM pickup. Position information is accessible at various configurable data rates. The instrument can output a real-time data stream and can be integrated with the machine protection system (Interlock detection).

Extensions: Interlock output, real-time data streaming, analog output, digital (serial) I/O.

The front and back panel of the Libera Spark HL are identical to those shown in Figure 4.

Table 1: Technical specifications of hadron beam position monitors

	For CIRCULAR machines		For LINEAR machines	
	Libera Spark HR	Libera Hadron	Libera Spark HL	Libera Single Pass H
General product code	LSHR	LHAD	LSHL	LSPH
Capabilities				
BPM slots	1	1 - 4	1	1 - 4
Supported input frequency range	<35 MHz/<45 MHz	<55 MHz	<750 MHz	<700 MHz
A/D conversion	125 MHz/14 bit	250 MHz/16 bit	125 MHz/14 bit	130 MHz/16 bit
Cooling	Passive	Active (fans)	Passive	Active (fans)
Power supply	PoE	110/220 V, 250 W	PoE	110/220 V, 250 W
Timing signals	Electrical (up to 3) *	Electrical (4)/Optical	Electrical (up to 3) *	Electrical (4)/optical
Fast data links	RJ-45	RJ-45 & SFP	RJ-45	RJ-45 & SFP
Maximum input signal *	<1.2 V peak pulse voltage *	<2 V peak pulse voltage *	<+10 dBm *	<+10 dBm *
Input gain/attenuation	Programmable, 31dB	Fixed	Programmable, 31dB	Fixed
Temperature drift, typical	<2 $\mu\text{m}/^\circ\text{C}$	<2 $\mu\text{m}/^\circ\text{C}$	<1 $\mu\text{m}/^\circ\text{C}$	<1 $\mu\text{m}/^\circ\text{C}$
Position RMS at bunch-by-bunch data rate	10 μm **	6 μm **	/	/
Position RMS at fast 10 kHz data rate	/	<1 μm **	/	/
Position RMS at slow 10 Hz data rate	/	<1 μm **	/	/
Position RMS at 1 MHz data rate		/	<1 μm	<3 μm , <0.03 °
Dimensions	H: 1 U, W: 9.5" (rack mountable with a kit), D: 210 mm	H: 2 U, W: 19" (rack mountable), D: 310 mm	H: 1 U, W: 9.5" (rack mountable with a kit), D: 210 mm	H: 2 U, W: 19" (rack mountable), D: 310 mm
* Can be extended/customized depending on user requirements				
** Measured with K=10mm				
Functionalities				
Bunch-by-bunch processing	Yes	Yes	No	No
Real-time data streaming	Optional *	Optional *	Optional *	Optional *
Slow data	No	Yes	No	No
Gain control	Yes	Libera Amplifier 110, external variable gain amplifier	Yes	No
Selectable processing window	Yes	Yes	Yes	Yes
Processing delay	Yes	Yes	Yes	Yes
Multi-chassis synchronization	Trigger-based	Reference clock with PLL	Trigger-based	Trigger-based
Data time stamping	Trigger-counter	Based on external RF clock	Trigger-counter	Trigger-counter
Interlock detection and output	Optional **	No	Optional **	Yes
Postmortem capability	No	Yes	No	Yes
FFT/FFT peak	No	Yes	No	No
Single-pass measurement	Yes	Yes	Yes	Yes
Additional Digital I/O channels and Analog output	Optional **	No	Optional **	No
Closed Orbit Feedback Application	No	Yes, see page 38	No	No
* Requires additional module	GbE interface	GDX module	GbE interface	GDX module
** Requires additional module	DAI module		DAI module	

ELECTRON

Beam Position Monitor Electronics

Instruments intended for use in linear and circular electron machines are shown in Figure 5 and Figure 6. Several versions are available, based on different technology and form factors. They provide different levels of measurement performance and functionalities. The BPM pickup types supported are button, stripline, and cavity-type pickups.

Figure 5: Example of a 3rd generation light source (synchrotron)

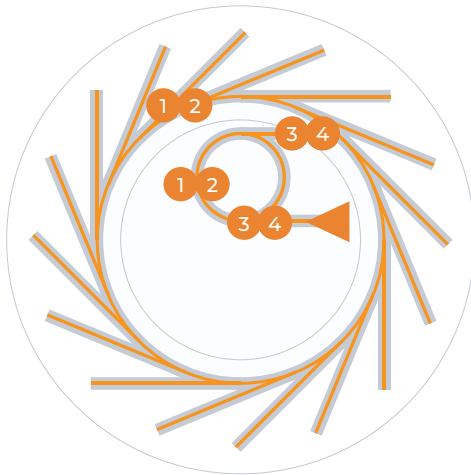
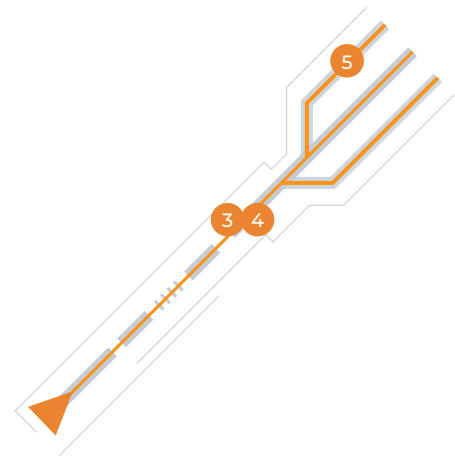

Figure 6: Example of a 4th generation light source (FEL/ERL)



1 Libera Brilliance+

Used in electron synchrotrons



More

Libera Brilliance+ is a beam position processor. The modular platform hosts up to four BPM modules (4 channels each), a timing module and a Gigabit Data Exchange (GDx) module. The main advantage of the Libera Brilliance+ is in its active mechanism that compensates the drift in electronics as well as in RF cables (using Libera XBS FE).

Extensions: Fast Orbit Feedback application, serial I/O interface.

Figure 7: Libera Brilliance+ front panel (block diagram)

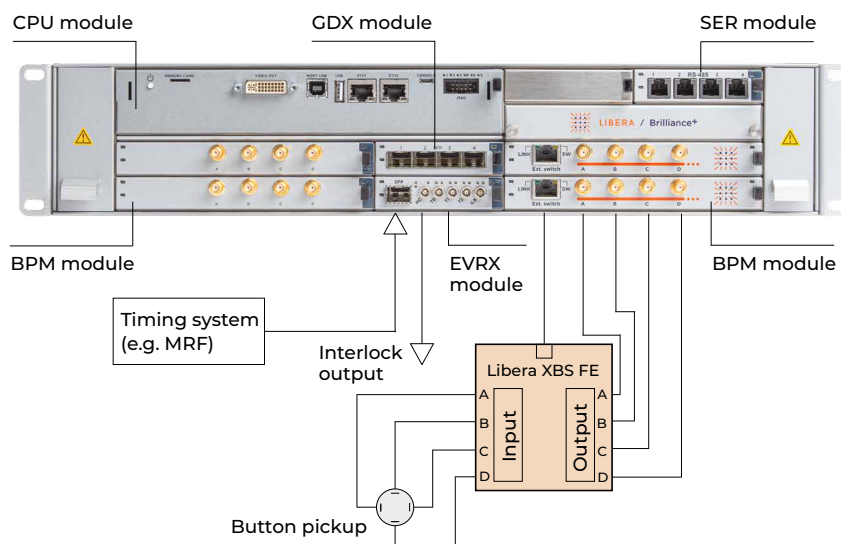

2 Libera Brilliance X

Used in electron synchrotrons



More

Libera Brilliance X is a beam position processor. The system is using various module types that run in the MTCA.4 chassis. It is designed for a high channel density and can connect to from two to twelve or more BPMs (depending on the MTCA.4 chassis configuration). The analog signal treatment is applied in the Libera XBS FE (at the BPM in the tunnel) first with more filtering and A/D conversion in the Libera 2BPMRTM module. Digital signal processing and timing signals are controlled by the DAMC-UNIZUP module. The processing modules of the Libera Brilliance X can run in parallel to general purpose AMCs in the same chassis where other BPM-related functionalities can be implemented (like FOFB).

Figure 8: Libera Brilliance X front panel and back panel

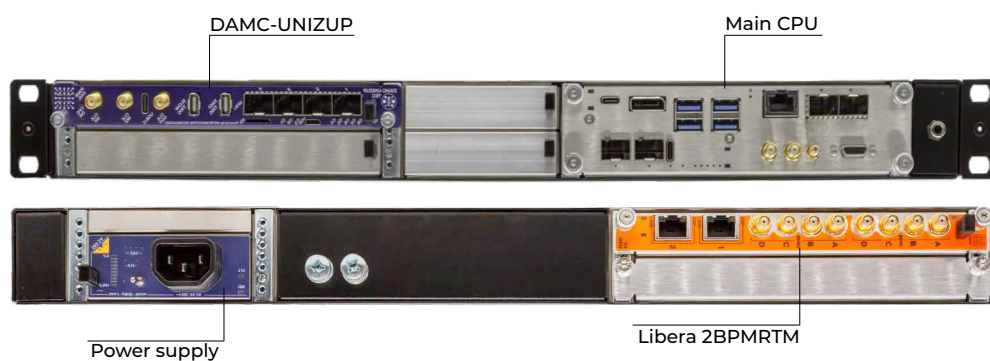

Libera 2BPMRTM

MTCA.4 Rear Transition Module



More

The module features 8 input channels with an analog front-end customized for the BPM application for electron synchrotrons. The input channels are equipped with a programmable attenuator and a combination of low-pass and band-pass filtering components. Typically, the central frequencies are around 352 MHz and 500 MHz but others can be supported, too. The 2 RJ-45 interfaces are intended for driving the Libera XBS FE.

Digitized signals are transferred through the D1.2 connector to the DAMC-UNIZUP module.

Figure 9: Libera 2BPMRTM front panel

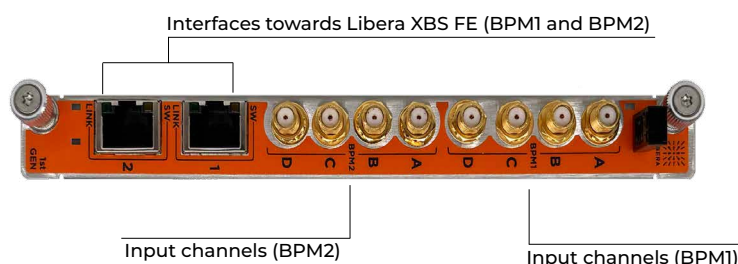



The DAMC-UNIZUP is a versatile, high-performance MTCA.4 AMC board based on AMD Zynq Ultrascale+ MPSoC, with the emphasis on the RTM I/O connectivity. The board was designed by DESY and industrialized by Instrumentation Technologies. It will be used for the BPM electronics of the PETRA IV project at DESY, where the signals from the BPM sensor are acquired and digitized by the Libera 2BPMRTM, and passed to the DAMC-UNIZUP through the Zone 3 connector. This makes the DAMC-UNIZUP a perfect AMC candidate for multi-channel signal processing applications like Beam Position Monitoring.

Figure 10: Libera DAMC-UNIZUP front panel

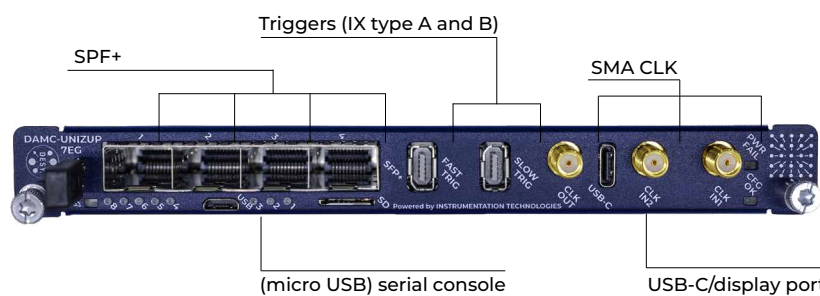

Table 2: Technical specifications of DAMC-UNIZUP

Capabilities	Details
MPSoC Options	AMD Zynq UltraScale+ XCZU7EG or XCZU11EG
CPU	Dual/Quad-Core ARM Cortex-A53, 1.2 up to 1.5 GHz*
Memory	4 GB DDR4 (PS) at 2400 MT/s + 4 GB DDR4 (PL) at 2666 MT/s*
PCIe	Gen 3 x4 or Gen3 x8 support, depending on RTM class configuration
Connectivity	4x SFP+ (12.5/16.375 Gbps), USB Type-C DisplayPort, USB 3.0, IX trigger and interlock connectors
Clocking	Flexible clocking with backplane (TCLK) and front-panel clock I/O, 2 PLLs and White Rabbit receiver support
Trigger Inputs	4x fast trigger differential inputs (LVDS, IX Type A) and 4x slow trigger inputs (RS-485, IX Type B) on the front panel
Storage	SD 3.0 (UHS) card slot (front panel) and 8 GB eMMC
Compliance	MTCA.4.1 D1.2/D1.3, full M-LVDS and DESY interlock support
Supported Tools	AMD Vivado, Petalinux, Yocto, SDSoc, and more
RTM class	D1.2 or D1.3 configuration support (assembly option)
Debug	Support for JSM via backplane, dual USB command line (front panel) and Serial-over-IPMI support

* The actual CPU core frequency is dependent on MPSoC Speed Grade. Connect with us for options not listed in this table

3 Libera Spark ERXR / ERPT

Used in electron synchrotrons



More

Libera Spark ERXR / ERPT is a beam position processor that supports the readout from a single BPM pickup (4 channels) and processes the data both in frequency and time domains. The ERPT version supports the Libera Pilot Tone FE and processes the input signals at two RF frequencies. The instrument can output a real-time data stream (e.g. at 10 kHz) and can be integrated with the machine protection system (Interlock detection). *Extensions:* Interlock output, real-time data streaming, analog output, digital (serial) I/O.

Figure 11: Libera Spark ERXR/ERPT front panel

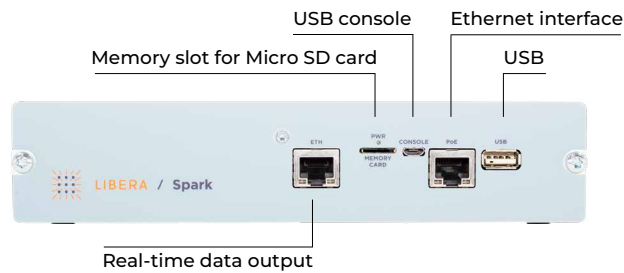

Figure 12: Libera Spark ERXR back panel (block diagram)

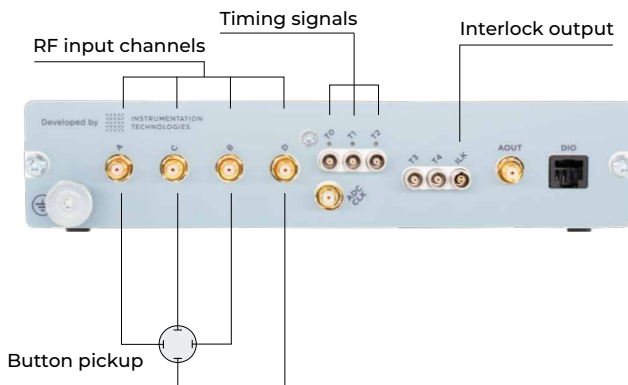
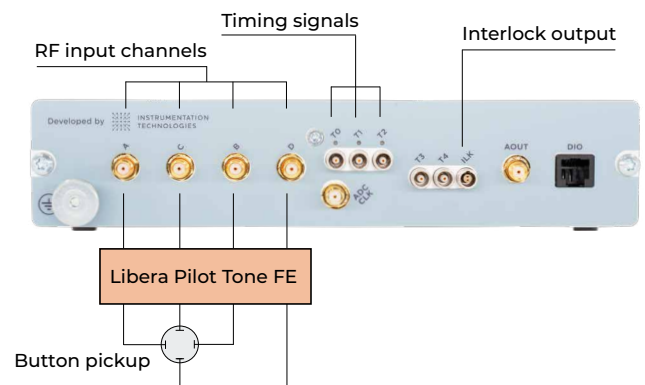

Figure 13: Libera Spark ERPT back panel (block diagram)



4 Libera Single Pass E

Used in electron LINACs



More

Libera Single Pass E is a single pass beam position processor. With its flexible digital signal processing, it can process various filling patterns from single bunch to CW and it can be integrated with the machine protection system (Interlock detection). The modular platform hosts up to four BPM modules, a timing module and optionally a gigabit data exchange (GDX) module for real-time data streaming.

Extensions: Real-time data streaming, serial I/O interface.

Accessories: Libera DWC.

Figure 14: Libera Single Pass E front panel (block diagram)

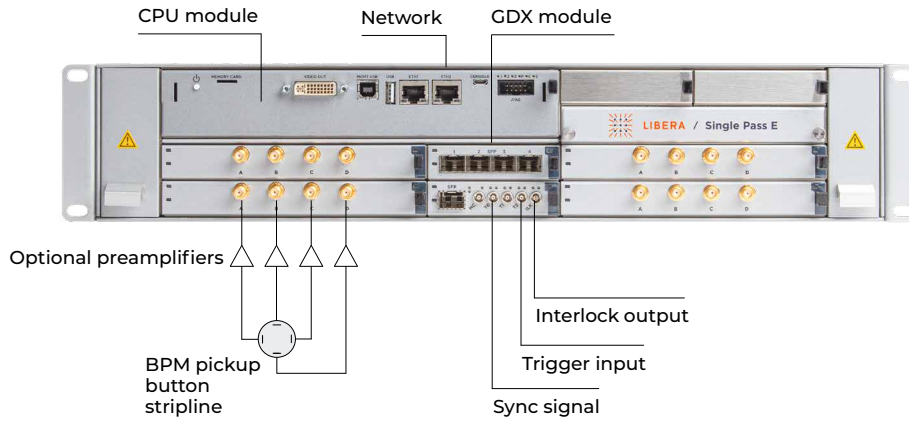

5 Libera Spark EL

Used in electron LINACs and transfer lines



More

Libera Spark EL is a beam position processor that supports the readout from a single BPM. With its flexible digital signal processing it can process various filling patterns from short macro-pulse to CW and deliver results at various configurable data rates. The instrument can output a real-time data stream and can be integrated with the machine protection system (Interlock detection).

Extensions: Interlock output, real-time data streaming, analog output, digital(serial) I/O.

Accessories: Libera DWC.

The front and back panel of the Libera Spark EL are identical to those shown in Figure 4.

6 Libera CavityBPM

Used in electron LINACs



More

Cavity beam position monitoring (Cavity BPM) offers superior position resolution for LINACs due to its resonant approach, which features a narrower bandwidth. This narrower bandwidth enhances signal strength by effectively filtering noise and amplifying the beam-induced response within the cavity's resonance frequency. However, to fully leverage these benefits, precise readout electronics are essential.

Figure 15 : Libera CavityBPM front and back panel

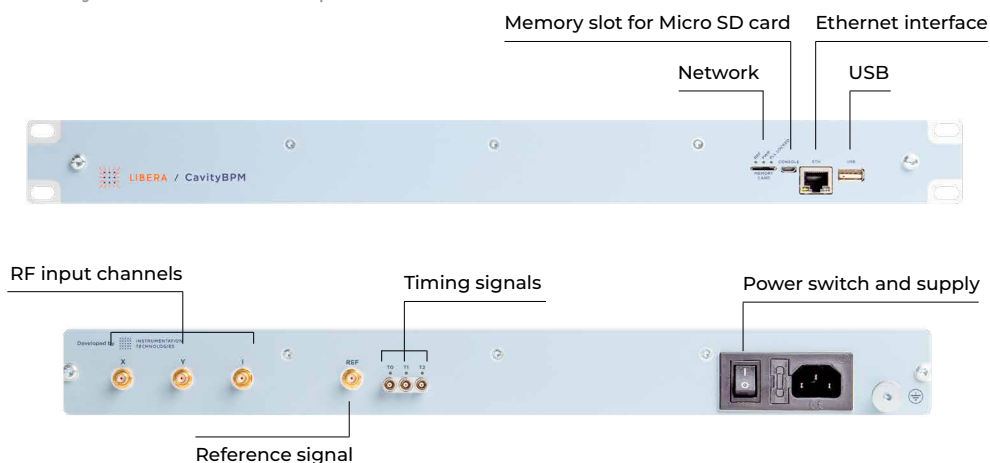

The Libera CavityBPM is specifically designed to process these cavity signals with high accuracy, ensuring reliable and precise beam position determination.

Extensions: Interlock output, real-time data SFP streaming

Table 3: Technical specifications of electron beam position monitors for circular machines

for CIRCULAR machines				
	Libera Spark ERXR	Libera Spark ERPT	Libera Brilliance+	Libera Brilliance X
General product code	LSXR	LSPT	LBRP	LBRX
Capabilities				
BPM slots	1	1	1 - 4	2 - 12
Supported input frequency range	<750 MHz	<750 MHz	<700 MHz	<700 MHz
A/D conversion	125 MHz/14 bit	125 MHz/14 bit	130 MHz/16 bit	125 MHz/16 bit
Cooling	Passive	Passive	Active (fans)	Active (fans)
Power supply	PoE	PoE	110/220 V	110/220 V
Timing signals	Electrical (3) *	Electrical (3) *	Electrical (4)/Optical	Electrical (4)
Calibration	Manual	Pilot Tone ****	Crossbar switch DSC Libera XBS FE	Crossbar switch DSC Libera XBS FE
Fast data link	RJ-45	RJ-45	RJ-45 & SFP	SFP
Maximum input signal *	<+5 dBm continuous	<-10 dBm continuous	<+4 dBm continuous	<+4 dBm continuous
Input gain/attenuation	Programmable, 31 dB	Programmable, 31 dB	Programmable, 31 dB, automatic mode	Programmable, 31 dB, automatic mode
Temperature drift, typical	2 $\mu\text{m}/^\circ\text{C}$	<1 $\mu\text{m}/^\circ\text{C}$ ***	0.2 $\mu\text{m}/^\circ\text{C}$	0.2 $\mu\text{m}/^\circ\text{C}$
Position RMS at turn-by-turn data rate	0.3 μm **	1 μm ***	0.5 μm **	0.5 μm **
Position RMS at fast 10 kHz data rate	0.04 μm **	0.1 μm ***	0.07 μm **	0.07 μm **
Position RMS at slow 10 Hz data rate	0.02 μm **	0.05 μm ***	0.02 μm **	0.02 μm **
Position RMS at single bunch	<10 μm **	/	/	/
Position RMS at macro pulse/ continuous wave	/	/	/	/
Dimensions	H: 1 U, W: 9.5" (rack mountable with a kit), D: 210 mm	H: 1 U, W: 9.5" (rack mountable with a kit), D: 210 mm	H: 2 U, W: 19" (rack mountable), D: 310 mm	depends on 4MTCA. crate
* Can be customized				
** Measured with K=10 mm				
*** Depends on setup configuration				
**** Requires Libera Pilot Tone FE - see page 43				
Functionalities				
Bunch-by-bunch processing	No (only single bunch/single turn)			
Turn-by-turn processing	Yes	Yes	Yes, multi-bunch option	Yes, multi-bunch option
Real-time data streaming	Optional *	Yes	Optional *	Optional *
Slow data	Yes	Yes	Yes	Yes
Gain control	Yes	Yes	Yes (automatic)	Yes (automatic)
Multi-chassis synchronization	Reference clock with PLL	Reference clock with PLL	Reference clock with PLL	Reference clock with PLL
Data time stamping	Yes	Yes	Yes	Yes
Interlock detection and output	Optional **	Optional **	Yes	Yes
Postmortem capability	No	No	Yes	Yes
Single-pass measurement	No	No	Yes	Yes
Frequency down-conversion	Direct (with ADCs)	Direct (with ADCs)	Direct (with ADCs)	Direct (with ADCs)
Additional Digital I/O channels and Analog output	Optional **	Optional **	No	/
Closed Orbit Feedback Application	No	No	Yes, see page 38	Yes, see page 38
* Requires additional modules	GbE interface	GDX module	GbE interface	GDX module
** Requires additional modules	DAI module		DAI module	
*** Requires additional modules				Libera DWC

Table 4: Technical specifications of electron beam position monitors for linear machines

for LINEAR machines			
	Libera Spark EL	Libera Single Pass E	Libera CavityBPM
General product code	LSEL	LSPE	LCAV
Capabilities			
BPM slots	1	1 - 4	1
Supported input frequency range	<750 MHz	<700 MHz	<6.5 GHz
A/D conversion	125 MHz/14 bit	160 MHz/16 bit	500 MHz/14 bit
Cooling	Passive	Active (fans)	Passive
Power supply	PoE	110/220 V	110/220 V
Timing signals	Electrical (up to 3) *	Electrical (4)/Optical	Electrical (up to 3) *
Calibration	Manual/Static	Manual/Static	Manual/Static
Fast data link	RJ-45	RJ-45 & SFP	SFP (optional)
Maximum input signal *	<5 V peak pulse voltage	<7 V peak pulse voltage	16 dBm
Input gain/attenuation	Programmable, 31 dB	Programmable, 31 dB	Programmable, 31 dB
Temperature drift, typical	0.3 $\mu\text{m}/^\circ\text{C}$	0.3 $\mu\text{m}/^\circ\text{C}$	0.3 $\mu\text{m}/^\circ\text{C}$
Position RMS at turn-by-turn data rate	/	/	/
Position RMS at fast 10 kHz data rate	/	/	/
Position RMS at slow 10 Hz data rate	/	/	/
Position RMS at single bunch	4 μm **	1 μm **	<1 μm
Position RMS at macro pulse/continuous wave	<4 μm	<1 μm	<1 μm
Dimensions	H: 1 U, W: 9.5" (rack mountable with a kit), D: 210 mm	H: 2 U, W: 19" (rack mountable), D: 310 mm	H: 1 U, W: 19" (rack mountable), D: 236 mm
* Can be customized			
** Measured with K=10 mm			
*** Depends on setup configuration			
**** Requires Libera Pilot Tone FE - see page 43			
Functionalities			
Bunch-by-bunch processing	Yes	Yes	Yes
Turn-by-turn processing	No	No	No
Real-time data streaming	Optional *	Optional *	Optional
Slow data	No	No	No
Gain control	Yes	Yes	Yes
Multi-chassis synchronization	Trigger-based	Trigger-based	Trigger-based
Data time stamping	Trigger-counter	Trigger-counter	Trigger-counter
Interlock detection and output	Optional **	Yes	No
Postmortem capability	No	No	No
Single-pass measurement	Yes	Yes	Yes
Frequency down-conversion	Optional ***	Optional ***	Internal (with mixer)
Additional Digital I/O channels and Analog output	Optional **	No	No
Closed Orbit Feedback Application	No	No	No
* Requires additional modules	GDX module		
** Requires additional modules		DAI module	
*** Requires additional modules	Libera DWC	Libera DWC	

1 Libera Photon

Used in synchrotron and FEL beamlines



More

The Libera Photon serves as an X-ray beam position processor, designed to work with diamond detectors, blade XBPMs, and ionization chambers. It supports external bias source that is applied to each of its 4 input channels. Beam position information is available in several datarates, including precise turn-by-turn data, enabled by PLL-locking to the machine clock.

Additionally, Libera Photon features a RJ-45 interface, dedicated for real-time streaming of data, which can be used for FOFB or SOFB integration.

Figure 16: Libera Photon front and back panel

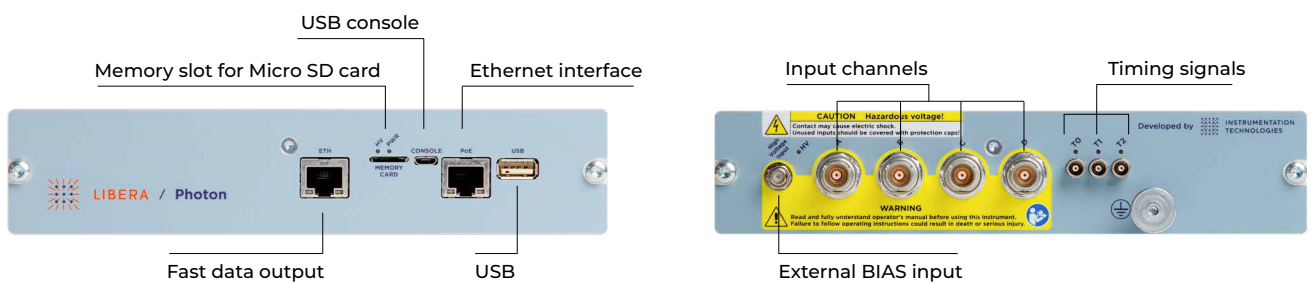

Table 5: Technical specifications of photon beam position monitors

General product code	LPHO
Capabilities	
Input channels	4
Current ranges	± 60 nA, ± 02 A, ± 2 A, ± 20 μ A, ± 200 A, ± 2 mA
Input frequency range	Depends on current data range, from 10 kHz to 80 kHz
A/D conversion	2.5 MHz/18 bit
Cooling	Passive
Power supply	PoE
Timing signals	LVTTTL (3.3 V), ~ 10 k Ω termination
External BIAS support	External bias support up to ± 150 V applied to input connectors
Fast data link	RJ-45, , can be used for FOFB or SOFB integration.
Maximum input signal	<2 mA
Temperature drift, typical	0.01 μ m/ $^{\circ}$ C
8-hour stability (23 $^{\circ}$ C, 200 μ A)	0.02 μ m
RMS uncertainty at 180 μ A (10 kHz data rate)	<0.02 μ m
RMS uncertainty at 180 μ A (10 Hz data rate)	<0.01 μ m
Dimensions:	H: 1 U, W: 9.5" (rack mountable with a kit), D: 210 mm
Functionalities	
Position calculation	Based on A,B,C,D inputs and pre-processing (dark current removal). Different pick-up configurations supported.
Post-mortem data storage	Upon an external T1 trigger event, data right before a critical event is stored.

BEAM LOSS MONITOR



1 Libera BLM



More

Libera BLM can process various types of beam losses, ranging from single particles to strong irregular losses, including both slow and fast losses. Along other signals, it provides data in precise turn-by-turn and bunch-by-bunch domains and it is capable of auto-detecting and counting individual pulses. Dedicated interlock detection processing and trigger outputs make it a vital piece of the Machine Protection System.

Figure 17: Libera BLM front and back panel

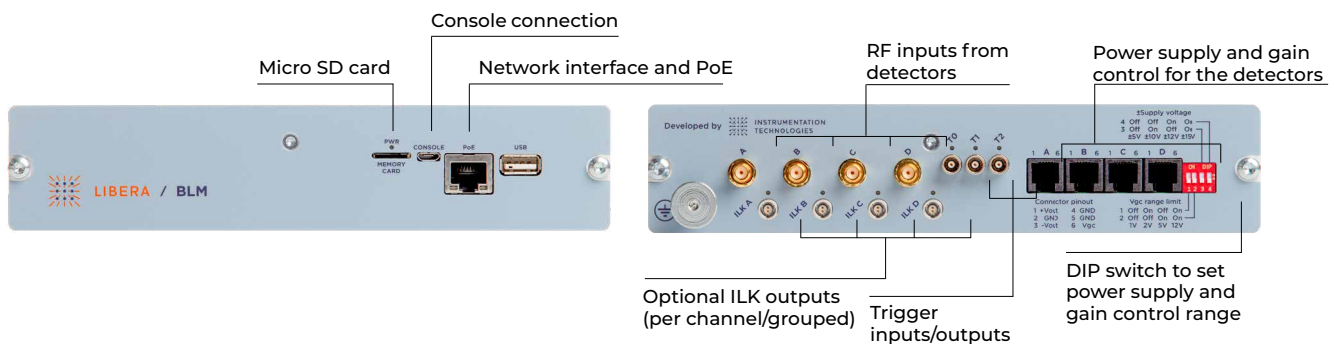

Various detector types can be connected to the 4 channels of Libera BLM, and it can also provide them with power and control voltages, allowing centralized regulation and calibration. Together with Libera BLD detectors, it forms a complete beam loss monitoring system.

Figure 18: Libera BLM block diagram

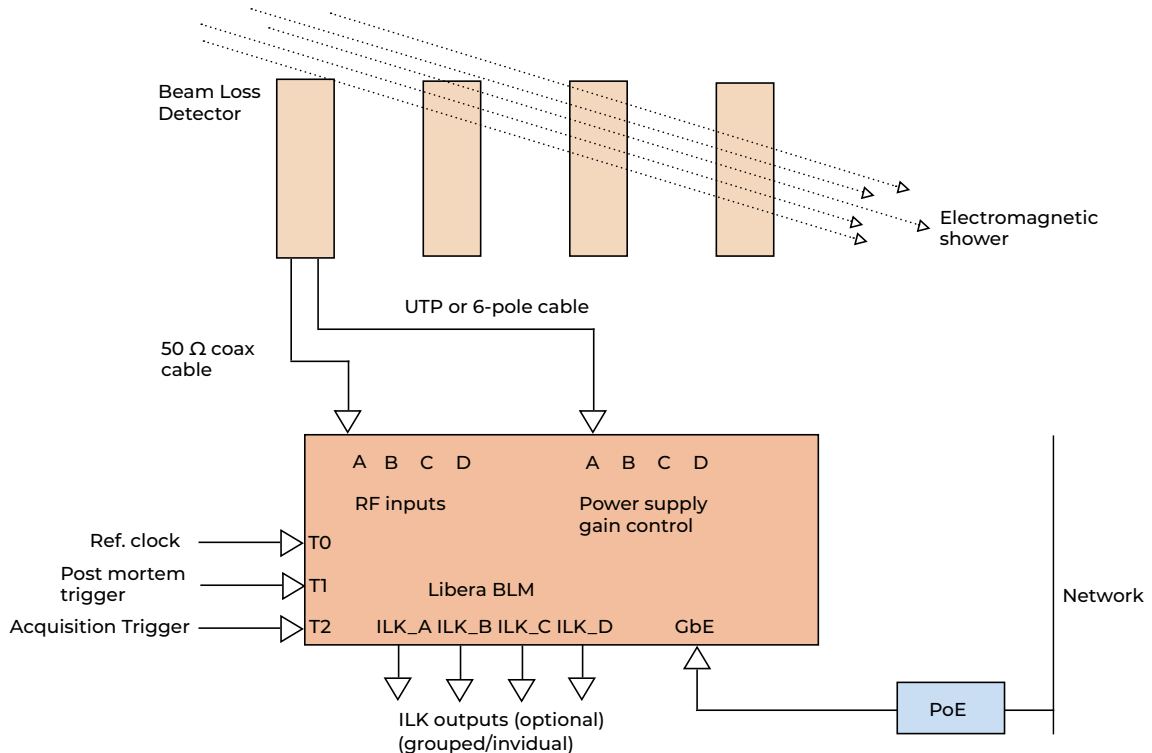

The Libera BLM provides power and gain control to up to four detectors (Libera BLD) which can be placed up to 100 m/330 ft away. Installation requires a 6-pole flat cable and a standard 50-Ohm cable. Detectors are optionally shielded by a 2 mm thick Pb shield.

Optionally, the Libera BLM can be provided with an Interlock detection functionality and can be integrated into the Machine Protection System.

Figure 19: Libera BLM signal processing

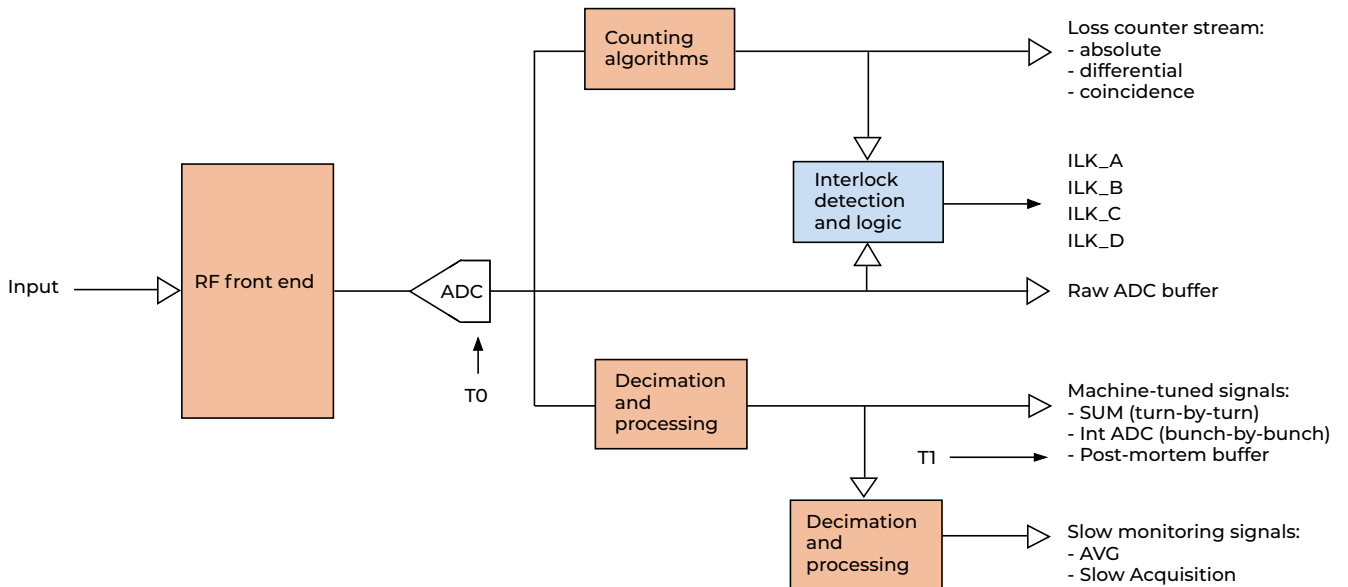

2 Libera BLD



More

Libera BLD is a beam loss detector, composed of a scintillator and a photomultiplier tube. Its key features include very fast response time (< 1 ns), dynamic range from single particles to strong losses, adjustable sensitivity and responsiveness to various radiation types: X-rays, gamma, beta and others. For light source applications, a lead shield is included to attenuate the background synchrotron radiation. The detectors are calibrated during the production and they integrate seamlessly with the Libera BLM readout electronics, which also provides them power and controls their sensitivity.

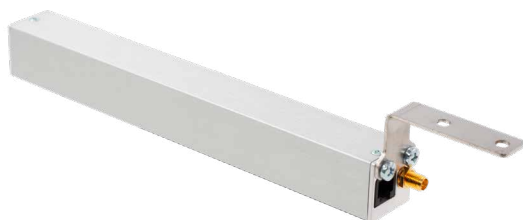

Figure 20 : Libera BLD (LBLD1.000.001)



Figure 21: Libera BLD (LBLD1.000.002 and LBLD1.000.003)

Special Libera BLD versions are available for neutron detection and for direct coupling with scintillating fibre beam loss detectors.

Table 6: Technical specifications of Libera BLM and the Libera BLD

Libera BLM			Libera BLD			
General product code	LBLM1.000.001	LBLM1.100.004	General product code	LBLD1.000.001	LBLD1.000.002 LBLD1.000.003	LBLD1.000.004
Capabilities			Capabilities			
Input channels	4		Scintillator material	EJ-200 scintillating rod	scintillating optical fibre	neutron-sensitive scintillator EJ-410
Input frequency range	~35 MHz large signal bandwidth ~50 MHz small signal bandwidth		Sensitivity to radiation type	X-ray, gamma, beta, ions ...	depends on fibre	neutrons
Input impedance	50 Ohm / 1 Mohm (fast / slow losses)		Scintillator emission peak wavelength	425 nm	depends on fibre	450 nm
A/D conversion	125 MHz/14 bit		PMT absorption peak wavelength	400 nm		
Cooling	Passive		PMT rise-time	0.57 ns		
Power supply	PoE		Supply voltage	5 V		
Timing signals	3x electrical, LVTTTL, 10kOhm		Gain control voltage	0 to 1 V		
Maximum input signal	±1.25 V @ 1M Ω ±5 V @ 50 Ω					
Dimensions	H: 1 U, W: 9.5" (rack mountable with a kit), D: 210 mm					
Input attenuation	0-31 dB					
Output channels	4x power supply (up to ±15 V) 4x gain control (up to +12 V)	4x power supply (up to ±15 V) 4x gain control (up to +12 V) 4 x differential LEMO connectors for interlock output (open-drain or 24 V)				
Functionalities						
Detection of slow and fast losses of low and high loss levels	Configurable input termination (50 Ohm / HiZ) and attenuation (0-31 dB) allow monitoring fast and slow losses of a wide range of magnitudes.					
Machine-tuned signal outputs	Loss data in turn-by-turn and bunch-by-bunch domain are available by locking the sampling clock to Machine Clock and setting the right decimation factors.					
Human-timescale signals	For everyday regular monitoring, AVG buffer, Slow Acquisition stream and Counter stream are available.					
Counting modes	Real-time algorithms detect and count individual loss pulses to provide a "counts-per-second" output. Coincidence counter monitors simultaneous events across channels.					
Signal customization	Signal processing can be customized by configuring various decimation factors, masks, windows and offsets.					
Calibration functionality	Configurable compensation for any differences across channels. Libera BLD detectors are calibrated during production.					
Auto-triggering acquisition	Automatic data acquisition upon a loss event detection.					
Synchronization	Synchronization of the machine times of all Libera instruments in the timing system.					
Power supply and control voltage output for detectors	Users don't need a separate power supply system for their detectors – it can be provided directly from the Libera BLM, along with gain control voltage.					
Post-mortem	Storing the data right before an interlock event: post-mortem buffer freezes writing upon an external T1 trigger or internal interlock event.					
Interlock detection and output		Based on real-time monitoring of the accumulated loss value or on counting mode. Output trigger for MPS is provided through 4 differential LEMO connectors, which can supply 24 V internally or work in open-drain configuration. Output can be per-channel or grouped.				

DIGITIZERS

Libera digitizers are designed to turn various raw detector signals into meaningful data and deliver it to user's control system. The instruments provide a base from which to develop users own application by combining their domain knowledge with our expertise in instruments design. All the building blocks from the analog front-end, FPGA processing, supporting firmware and software infrastructure, as well as the high-level user interface adapters form a working template with the possibility to extend its functionalities - allowing users to focus only on the core part: the signal processing algorithms. AC- and DC-coupled versions provide input bandwidths that suit both time-domain processing and narrow-band or frequency domain applications. The instruments are network-attached devices, with standard interfaces that facilitate integration into the control system (EPICS, TANGO, TCP-IP socket, HTTP etc.).

1 Libera Digit 125



More

The Libera Digit 125 is a 4 channel general-purpose digitizer and a sampling frequency of 125 MS/s with 14 bit resolution. Data is stored in a configurable buffer, with a maximum of 8 million data samples stored per channel.

Figure 22: Libera Digit 125 front and back panel

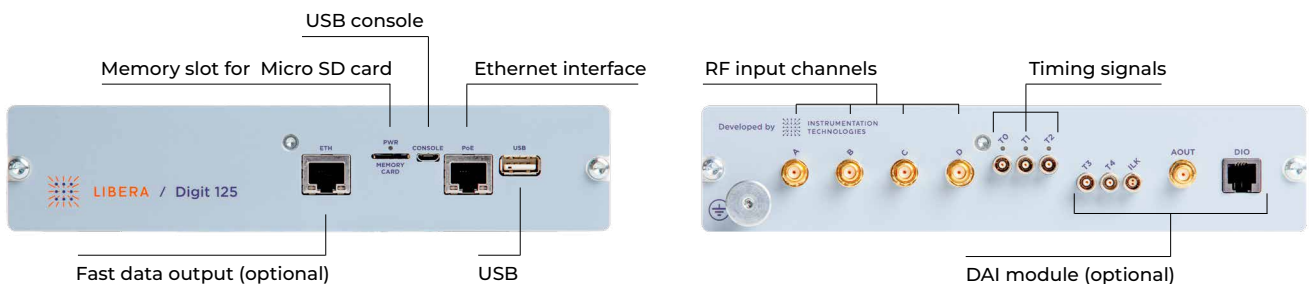
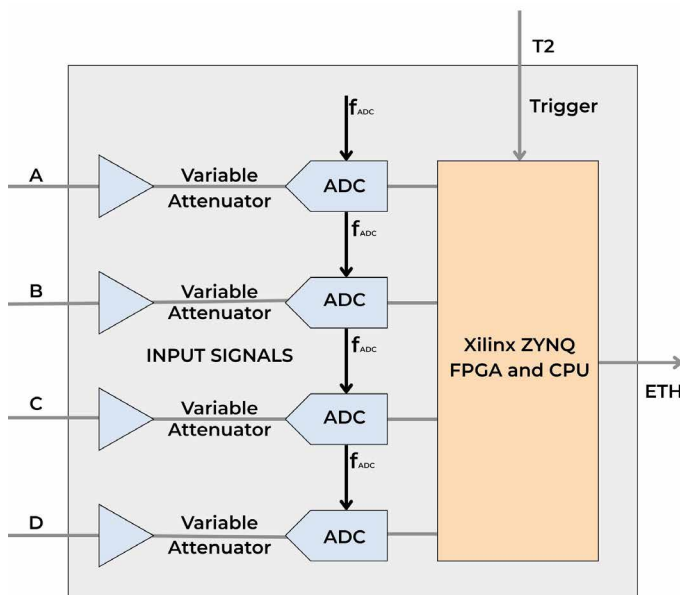

Figure 23: Libera Digit 125 block diagram



- 4 independent input channels
- 125 MS/s and 14 bit resolution ADCs
- AC coupled and DC coupled versions
- DC version includes a 31 dB variable attenuator
- Support for EPICS, TANGO
 - post-mortem functionality
 - processing: averaging to 5MS/s and 1MS/s
 - global machine time synchronization

2 Libera Digit 500



More

When higher sampling rates and more powerful, platform is required, Libera Digit 500 is the preferred instrument. It can perform as a low-noise and wide dynamic range digitizer with 4 channels. Additionally Libera Digit 500 can be used as Beam Current Monitor (see page 23).

The data is stored in a configurable segmented buffer, with different acquisition modes and trigger rates up to 1 kHz. The instrument is available in AC and DC coupled version. It can optionally provide 4 SFP ports for fast ADC data streaming.

Figure 24: Libera Digit 500



Table 7: Technical specifications of digitizers

	Libera Digit 125		Libera Digit 500	
Variant	DC	AC	DC	AC
General product code	L1251.00D	L1251.00A	L5001.00D	L5001.00A
Capabilities				
Channel number	4	4	4	4
Sampling frequency [MS/s]	125	125	500	500
Resolution [bit]	14	14	14	14
BW	DC-40 MHz	10 MHz-700 MHz	DC-250 MHz	1 MHz-2 GHz
Coupling	50 Ω/1M Ω	50 Ω	50 Ω	50 Ω
Max input	±5 V @ 50 Ω, 1.25 V @ 1M Ω	1 V/10 dBm	1 V/10 dBm	1 V/10 dBm
Input gain / attenuation	0-31 dB		0-31 dB	0-31 dB
Triggering level	3.3 V TTL LEMO	3.3 V TTL LEMO	3.3 V TTL LEMO	3.3 V TTL LEMO
Max trigger frequency [Hz]	2	2	500 (can be extended up to 1000)	500 (can be extended up to 1000)
Reference clock	Yes	No	Yes	Yes
FPGA	AMD Zynq 7020	AMD Zynq 7020	AMD Zynq 7035	AMD Zynq 7035
PoE	Yes	Yes	No	No
Access interfaces	SSH/TANGO/EPICS/ HTTP/ LabView Python/Matlab	SSH/TANGO/EPICS/ HTTP/ LabView Python/Matlab	SSH/TANGO/EPICS/ HTTP/ LabView Python/Matlab	SSH/TANGO/EPICS/ HTTP/ LabView Python/Matlab
Available extensions	DAI1 module	DAI1 module	DAI1 module SFP connectors	DAI1 module SFP connectors
Max acquisition length [samples]	8 M	8 M	~500 M	~500 M
Dimensions	H: 1 U, W: 9.5" (rack mountable with a kit), D: 210 mm	H: 1 U, W: 9.5" (rack mountable with a kit), D: 210 mm	H: 2 U, W: 19" (rack mountable), D: 236 mm	H: 2 U, W: 19" (rack mountable), D: 236 mm

BEAM CURRENT MONITOR

1 Libera Digit 500



More

Libera beam current monitors and provide users with several powerful options for readout and processing of signals from beam charge or beam current measurements, which are typically detected using integrated current transformer sensors (ICTs) or even beam position monitor pickups. With a sampling rate of 500 MHz, external reference locking and phase shifters for fine-tuning, our instrument handles even the fastest signals and turns them into meaningful data with up to bunch-by-bunch resolution. The instrument is network-attached and supports various communication protocols that enable seamless control system integration.

Figure 25: Libera Digit 500 back and front pannel

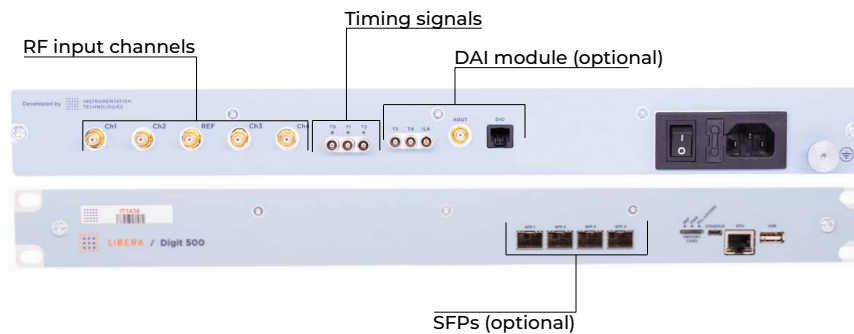

AC and DC coupled versions are available and 4 optional SFP ports for fast data streaming can be provided. Common point for all associated use-cases is pulse processing, but based on user requirements, Libera Digit 500 supports four applications:

1. Linacs and transfer lines: pulse auto-detection and characterization

Figure 26: Pulse processing algorithm and processing scheme

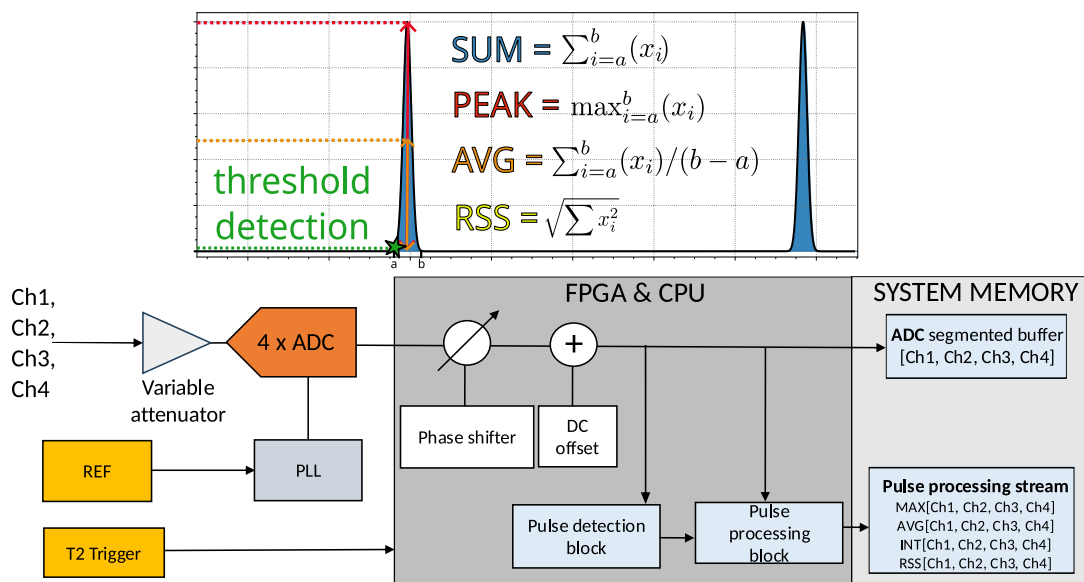

2. Synchrotrons: Fill pattern monitor with bunch-by-bunch resolution

Figure 27: Averaged bunch-by-bunch charge setup and processing

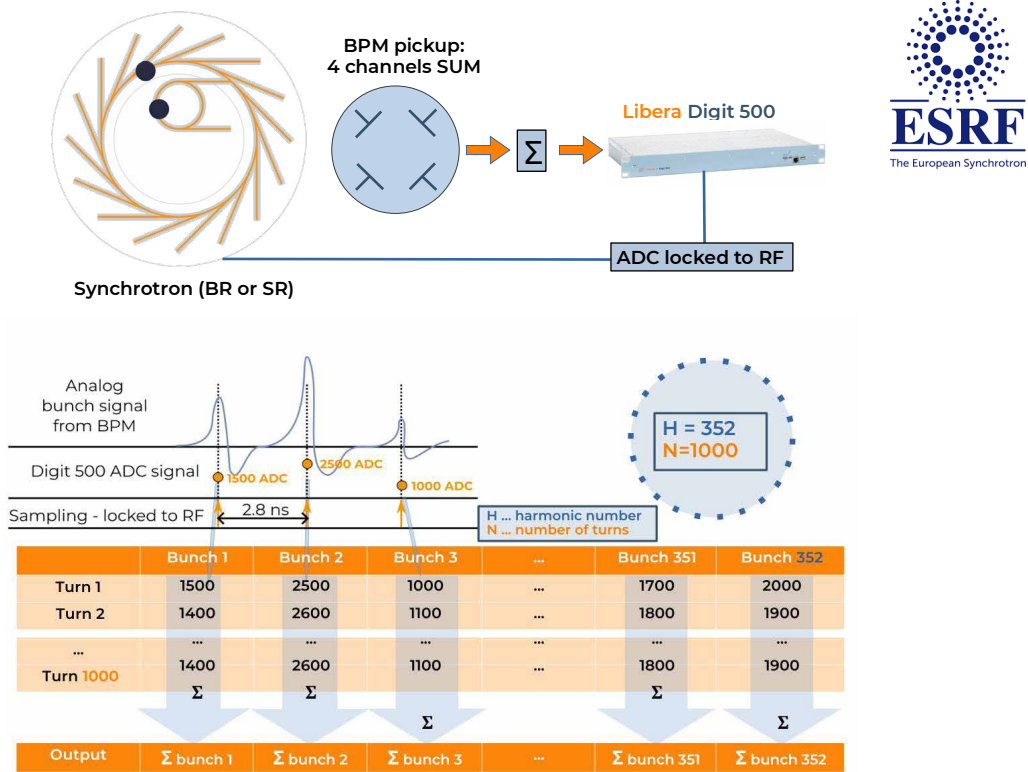

3. Resonant cavity beam current monitor:

- turn-key solution with Bergoz (CR-CDS)
- digital down conversion: mixing with REF signal and IQ demodulation for precise amplitude extraction (lock-in detection).

Figure 28: Resonant cavity beam current monitor (CR-CDS) setup and processing

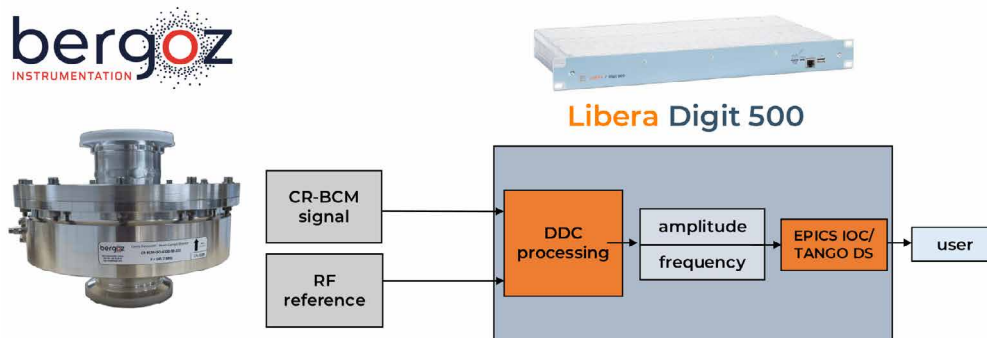

4. Advanced users: custom design.

We have expertise in combining users domain knowledge with our knowledge of instrumentation design. Based on that, Libera Digit 500 can be treated as a starting-point platform to which various tailored features can be added or functionalities extended. More information is available in the Digitizers section.

CURRENT METER



More

1 Libera Current Meter

The Libera Current Meter is a 4 channel, general purpose current meter with an operating range from sub-nA to 2 mA.

It is applicable as a readout device for various detector types, including blades, diamonds, fission chambers, SPND and Faraday cups. With a 2.5 MS/s sampling rate and 18-bit ADC resolution, it allows high-precision monitoring of rapid effects. The digital signal processing includes several stages of averaging, allowing users to record short events as well monitor data on a human timescale. Built-in adapters enable seamless integration with the user's control systems (EPICS, TANGO, etc ...). TRIAX version allows high voltage bias for the detectors up to +/- 150 V.

Figure 29: Libera Current Meter front and back panel (BNC and TRIAX connectors versions)

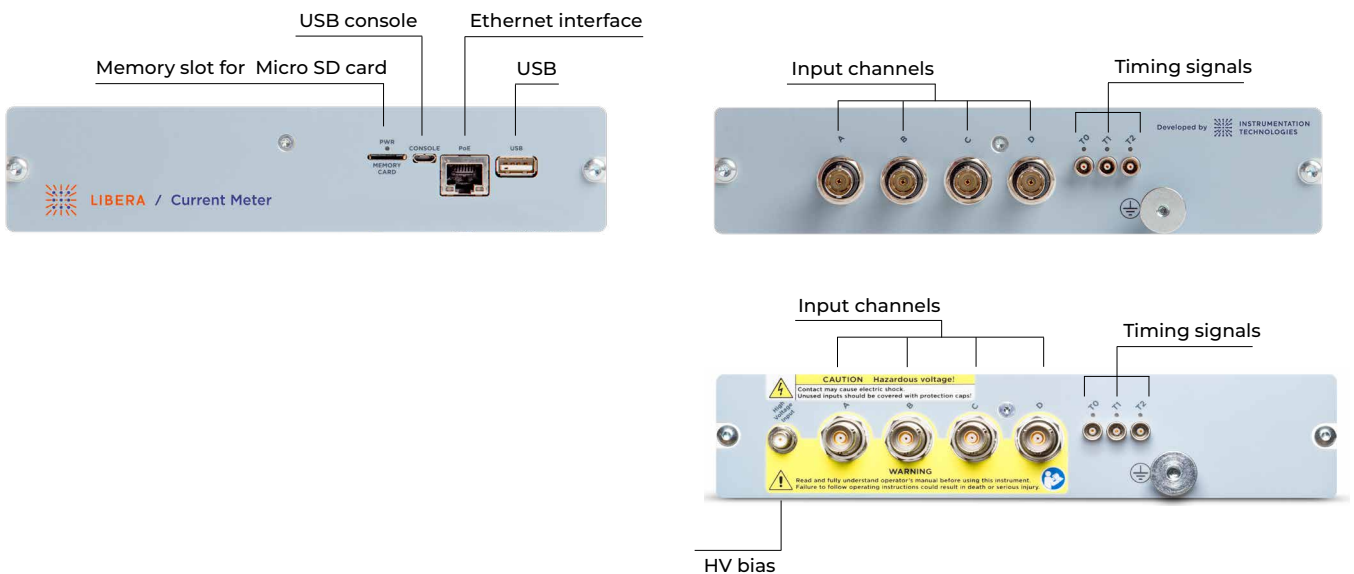

Figure 30: Libera Current Meter digital signal processing

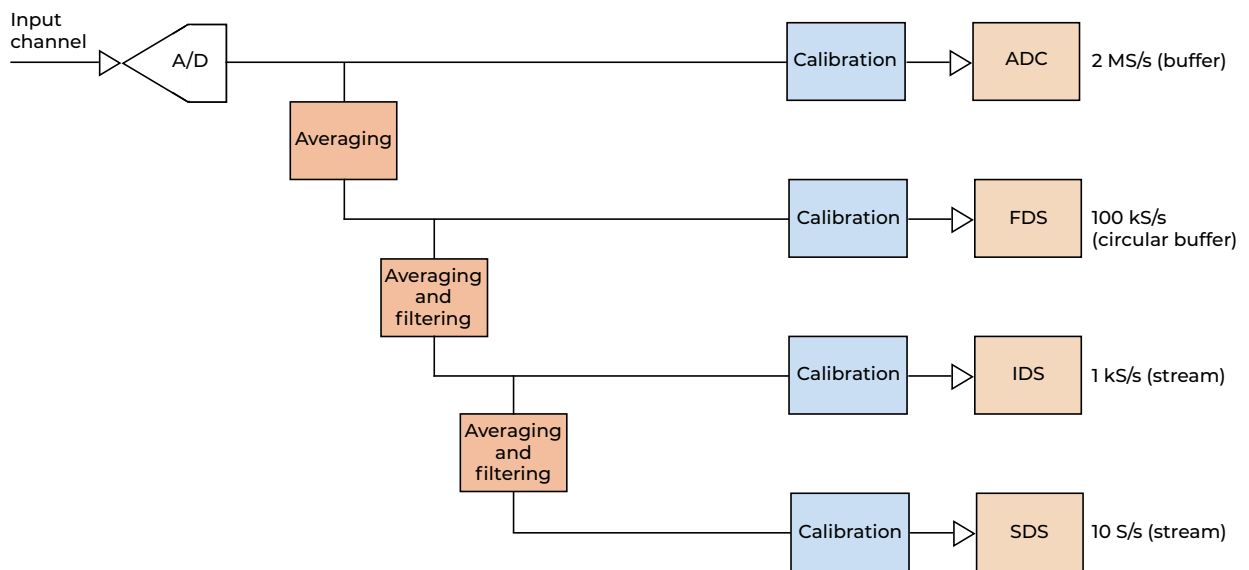

Table 8: Technical specifications of the Libera Current Meter

Variant	BNC version	TRIAx version
General product code	LCMB	LCMT
Capabilities		
Input channels	4	
Current ranges	± 60 nA, ± 0.2 μ A, ± 2 μ A, ± 20 μ A, ± 200 μ A, ± 2 mA	
Input frequency range	Depends on current range, from 10 kHz to 90 kHz	
A/D conversion	2.5 MHz (default 2 MHz)/18 bit	
Cooling	Passive	
Power supply	PoE	
Timing signals	LVTTTL (3.3 V), ~ 10 k Ω termination	
High voltage polarization (needs an external high voltage source)	No	Support up to ± 150 V
Temperature drift, typical	< 1 %/ $^{\circ}$ C	
8-hour stability (1 $^{\circ}$ C) (23 $^{\circ}$ C, 1 μ A)	30 nA peak-to-peak	
RMS uncertainty @ 1 μ A (slow 10 Hz data)	< 50 pA	
RMS uncertainty @ 1 μ A (slow 10 Hz data)	< 50 pA	
Dimensions	H: 1 U, W: 9.5" (rack mountable with a kit), D: 210 mm	
Functionalities		
WebGUI	Easy access is provided by a WebGUI: to connect and acquire data it is sufficient to simply connect to the instrument using a web browser.	

DIGITAL LLRF



More

1 Libera LLRF

The Libera LLRF is a digital processing and feedback system that monitors and stabilizes the quality of the beam acceleration by controlling the phase and amplitude of the RF field injected into the machine accelerating structures. Being designed to be modular and reconfigurable, the system can fit the exact requirements of any kind of accelerator, providing three core functions: stabilization of the cavities' RF fields, keeping the cavities at resonance through tuning, and machine diagnostics for signal analysis and event monitoring.

Figure 31: Libera LLRF front panel

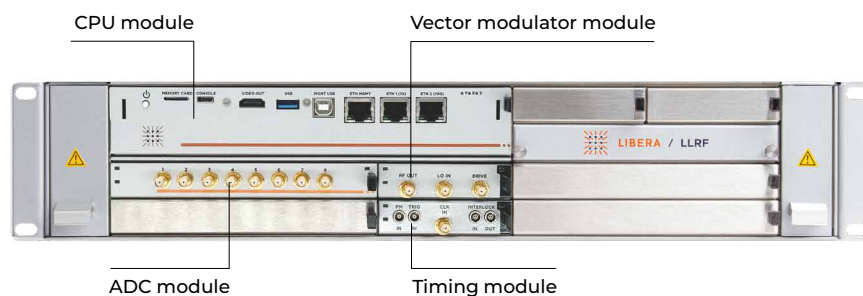

The system can incorporate up to four ADC modules, with the channel configuration (6 or 8 channels per module) depending on the version. This setup enables the processing of a total of 24 to 32 channels. Depending on signal requirements, the number of ADC modules can be adjusted accordingly.

Figure 32: Possible configuration of Libera LLRF in the accelerator environment

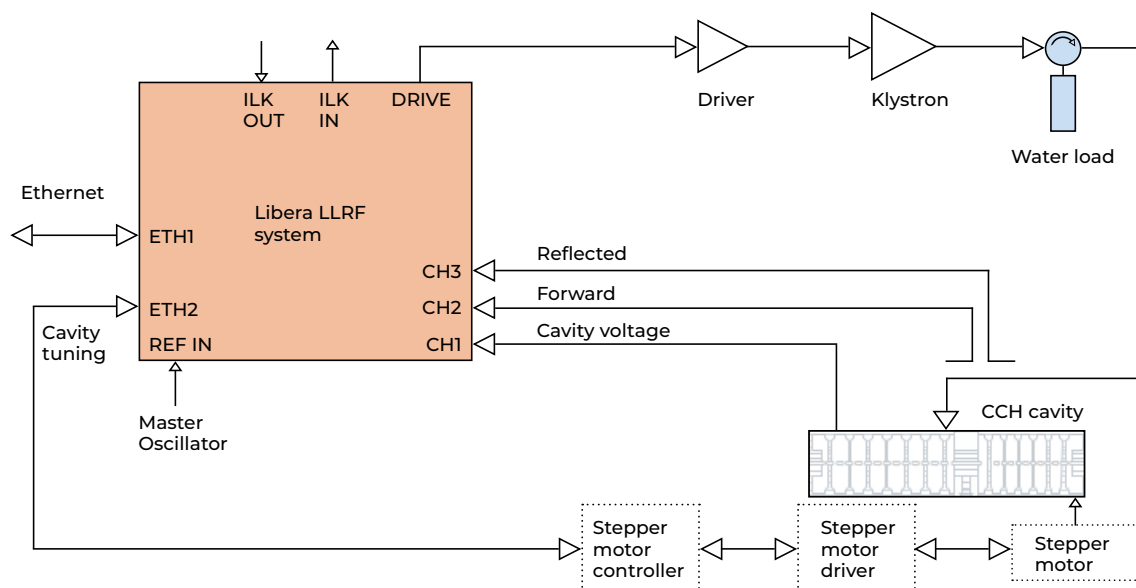
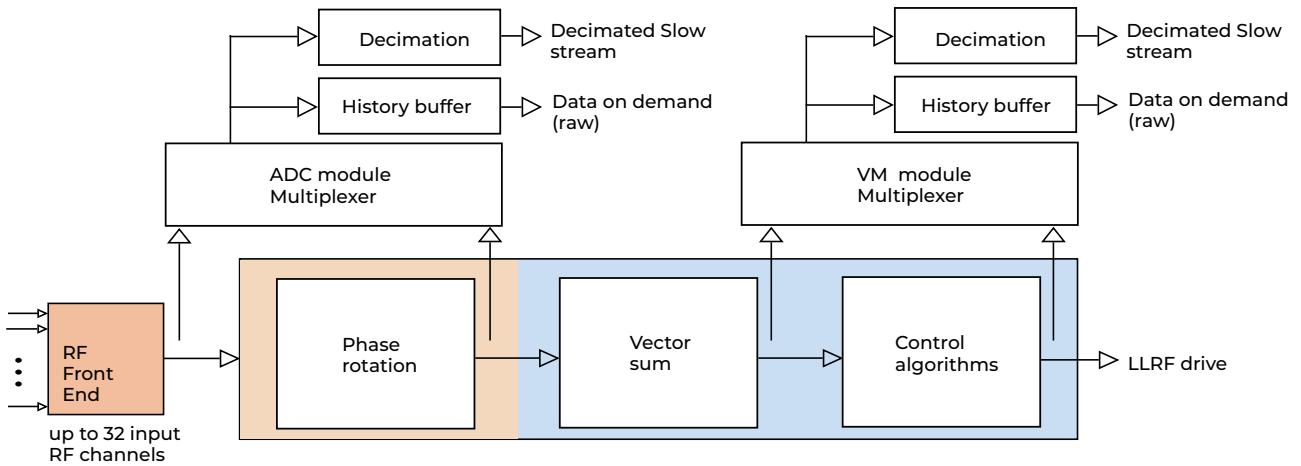

Figure 33: Libera LLRF system signal processing



The phase rotation block ensures calibration of each input signal's phase and amplitude, mitigating the impact of RF cabling variances and beam time delays on LLRF control. This functionality supports both intra-pulse and pulse-by-pulse feedback mechanisms, typically applied to either individual signals or the vector sum of all signals. The vector sum combines all acquired signals into one unified input for the control algorithm. The signals acquired by the Libera LLRF can be also used for diagnostics purposes and represented with the expert GUI provided with the instrument.

Table 9: Technical specifications of the Libera LLRF system

General product code	LLRF
Capabilities	
RF input channels	Up to 24/32 channels (6/8 channels per ADC module)
RF input frequency	Up to 12 GHz
Maximum RF power input	+20 dBm
A/D conversion	130 MSps/250 MSps (16 bits)
FPGA processing	Xilinx Kintex Ultrascale
RF output channels	2 (1 RF drive, 1 auxiliary)
Maximum RF drive output power	+10 dBm
Cooling	Active (Forced Air)
Power supply	110/220 V
Dimensions	Libera LLRF processing unit: H: 2 U, W: 19" (rack mountable), D: 310 mm Libera TSRF: H: 2U, W: 19" (rack mountable), D: 456 mm
Functionalities	
Supported modes of operation	Pulsed Continuous Wave (CW)
Feedback and control	Intra-Pulse and Pulse-by-pulse feedback Beam loading compensation Power amplifier non-linear response compensation
Cavity tuning	Directional coupler based detuning calculation and cavity field decay analysis Slow tuning PID controller and different stepper-motor interfaces support
Machine protection	Low-latency interlock interface (Input and Output) with failsafe logic
Temperature stabilization	Temperature stabilized RF front-end option
Amplitude stability	< 0.01 % RMS*
Phase stability	< 0.01° RMS*
Latency (input to drive output)	Down to 250 ns
Long-term temperature stability with temperature stabilized RF front-end	<100fs RMS/72 hours
* Pulse-by-pulse performance	

Figure 34: Optional Libera LLRF TSRF (temperature stabilized RF front-end) front panel

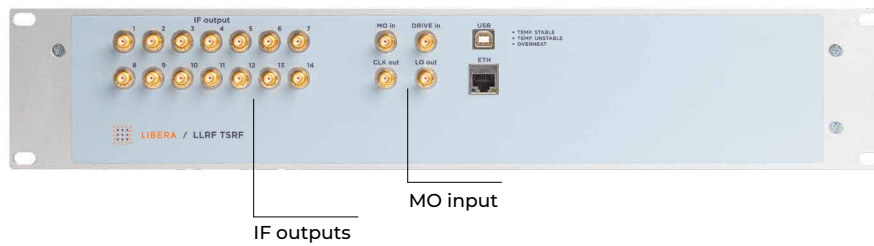

Figure 35: Optional Libera LLRF TSRF (temperature stabilized RF front-end) back panel



2 Libera TSU



More

The Libera TSU (Trigger Synchronization Unit) is designed to ensure precise distribution and synchronization of electrical trigger signals, eliminating asynchronous triggering and associated jitter by re-synchronizing triggers with the Master Oscillator.

The device not only synchronizes externally provided triggers, such as asynchronous signals, but also allows individual fine-tuning of trigger outputs to optimize machine timing—for example, adjusting the timing advance and pulse duration for RF modulators and preamplifiers. With 26 trigger input lines and 39 output trigger lines, the system provides flexible signal distribution and timing adjustments. Additionally, the Libera TSU can function as a standalone timing system, internally generating triggers harmonically related to the Master Oscillator and synchronized with the AC mains.

Figure 36: Libera TSU front panel and back panel

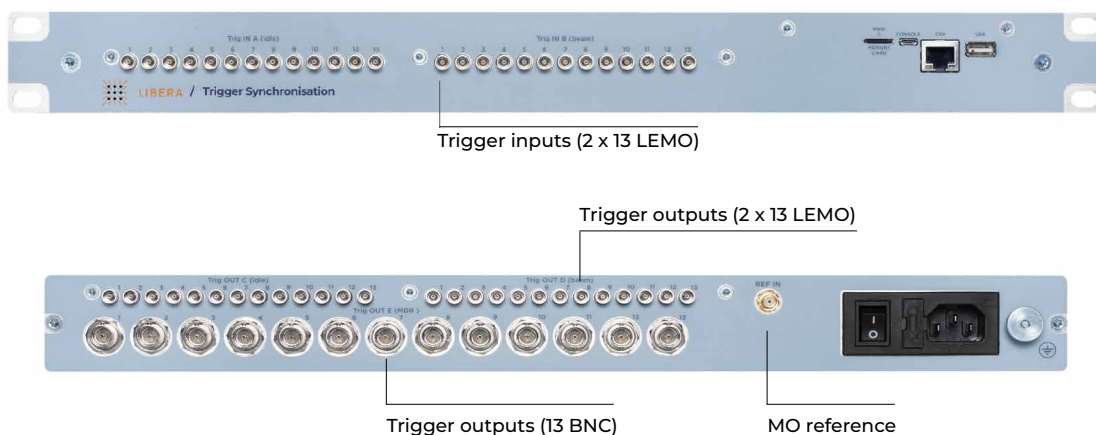

SYNCHRONIZATION

Synchronization of different devices e.g. LLRF stations along an accelerator is crucial for its operation. It is achieved by means of reference RF signals. A synchronization system typically consists of the following building blocks:

- A reference master oscillator, which serves as a common source of the reference RF signal for all devices
- Distribution amplifiers split and generate all RF reference signals that can be used by multiple devices
- Reference transfer systems enable to transfer the reference signals over longer distances while preserving the required quality

Figure 37: Synchronization system typical topology

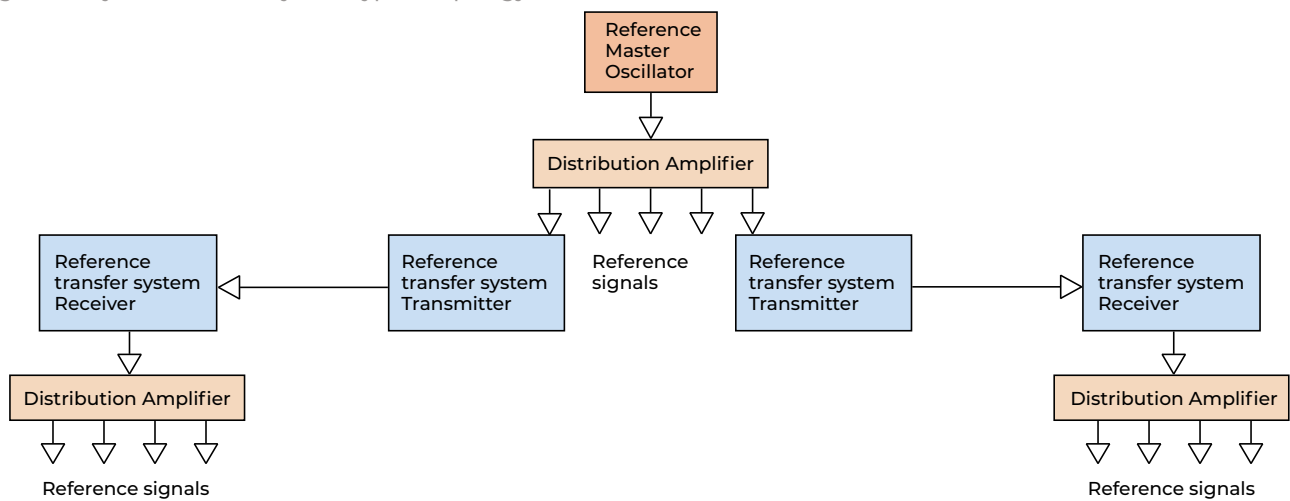

1 Libera RMO



More

The Libera RMO - Reference Master Oscillator is a low phase noise and stable source of an RF signal, which can be used as a reference signal for synchronization of different devices (e.g. LLRF stations in an accelerator). The device free-runs on an internal Oven Controlled Crystal Oscillator (OCXO) which can additionally be locked to an external 10 MHz reference signal.

Figure 38: Libera RMO front and back panel

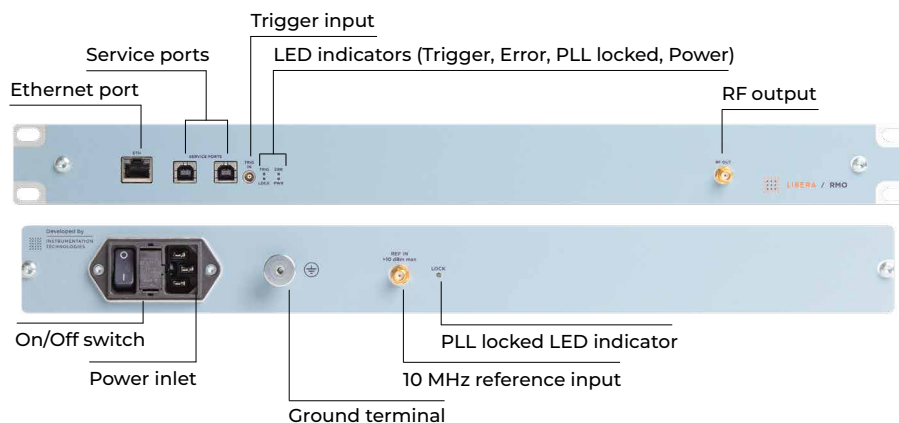

Figure 39 : Libera RMO block diagram

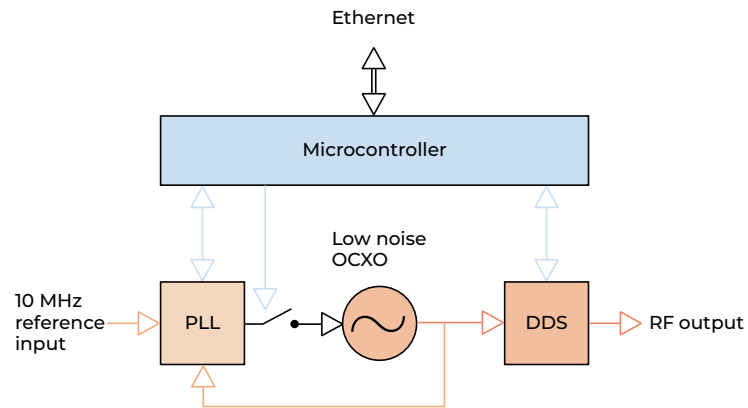

Table 10: Technical specifications of the Libera RMO

General product code	LRMO
Capabilities	
Supported frequency ranges	50 MHz - 3120 MHz
RF output	1, SMA connector, 50 Ω
Nominal RF output power	+15 dBm at least
RF output power stability	0.05 dB/K
Phase noise (integrated from 10 Hz to 10 MHz)	Max: <90 fs RMS Typically: 40 - 60 fs RMS
Harmonic suppression	<50 dBc up to the 5 th harmonic
Frequency stability (in free running mode)	5*10 ⁻¹¹ (Allan deviation)
RF output return loss	-15 dB
RF reference input	1, SMA connector, 50 Ω
RF reference input frequency	10 MHz ± 20 Hz
RF reference input power	-20 dBm - +10 dBm
PLL lock time	<30 s
Stability operation temperature range	20 - 25 °C
Operating relative humidity range	0 - 80 %
Dimensions	H: 1 U, W: 19" (rack mountable), D: 358 mm
Functionalities	
Locking to an external 10 MHz reference signal by means of a PLL	
Frequency sweep	
Frequency setting on trigger	
Remote control via Ethernet	
EPICS IOC	

2 Libera Distribution Amplifier



More

The Libera Distribution Amplifier serves to split an input RF signal to multiple output RF signals at specified output power levels. Additionally, by applying frequency multiplication, frequency division, and PLL, it also enables the generation of higher and sub harmonics coherent with the input RF signal. These functionalities are performed with minimum added jitter and assuring long-term phase stability.

Figure 40 Libera Distribution Amplifier front and back panel

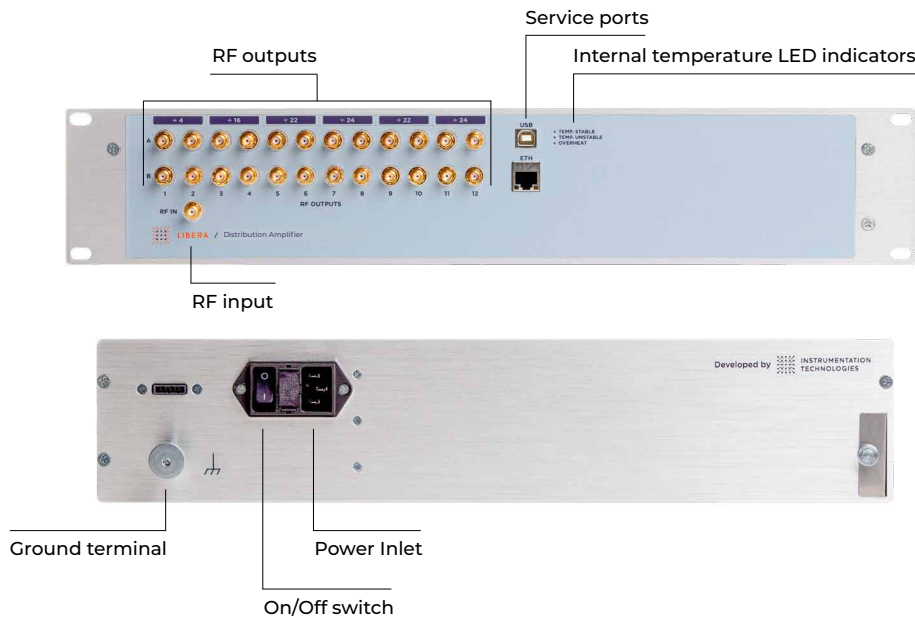

The modular design of the Libera Distribution Amplifier supports up to 6 custom output modules with up to 4 RF outputs each. The output modules can be customized to generate coherent harmonics according to the user's needs.

Figure 41: Libera Distribution Amplifier block diagram

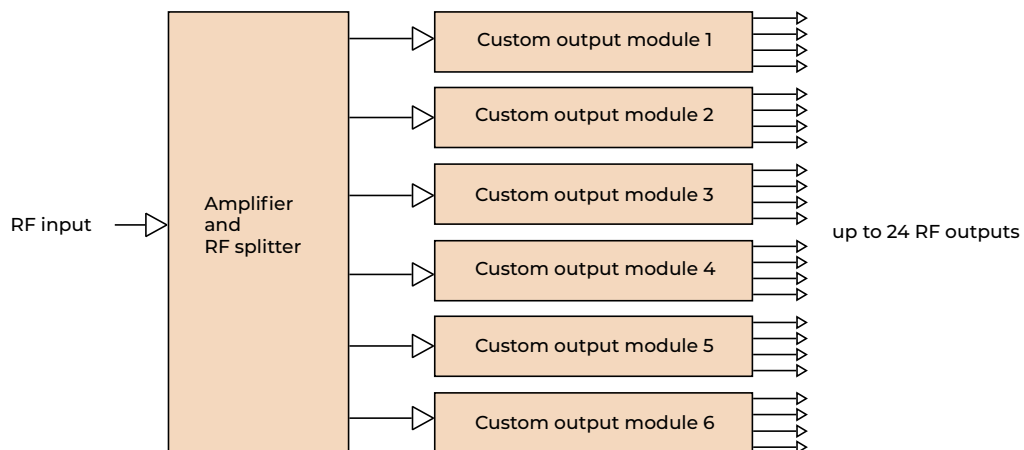

Table 11: Technical specifications of the Libera Distribution Amplifier

General product code	LMDA
Capabilities	
Supported input frequency ranges	50 MHz - 3120 MHz
RF input	1, SMA connector, 50 Ω
Nominal RF input power	+15 dBm ±1 dB *
RF outputs	Up to 24, SMA connectors, 50 Ω
Nominal power per RF output	+16 dBm ±1 dB
Added jitter (integrated from 10 Hz to 10 MHz)	<10 fs RMS **
Long-term drift between input and output (typical in 24 hours)	in the range of 10 fs
Long-term drift between two outputs (typical in 24 hours)	in the range of 10 fs
Operating temperature range	20 - 27°C
Operating relative humidity range	0 - 80 %
Dimensions	H: 2 U, W: 19" (rack mountable), D: 456 mm
* RF input power can be adapted to a fixed value down to +5 dBm	
** For outputs at ~3 GHz. Added jitter of the outputs at higher and sub harmonics depends on multiplication and division factors	
Functionalities	
RF signals amplification and fan-out	
Generation of harmonics coherent with the input RF signal	
Temperature stabilization to guarantee long-term phase stability	

3 Libera Sync



More

The Libera Sync is a continuous wave reference transfer system, which is used to transmit the RF signals over longer distances while preserving their high-quality in terms of low jitter and good long-term stability. The Libera Sync is based on the RF over fiber (RFOF) technology. It consists of a transmitter and a receiver unit.

Figure 42: Libera Sync Transmitter front panel

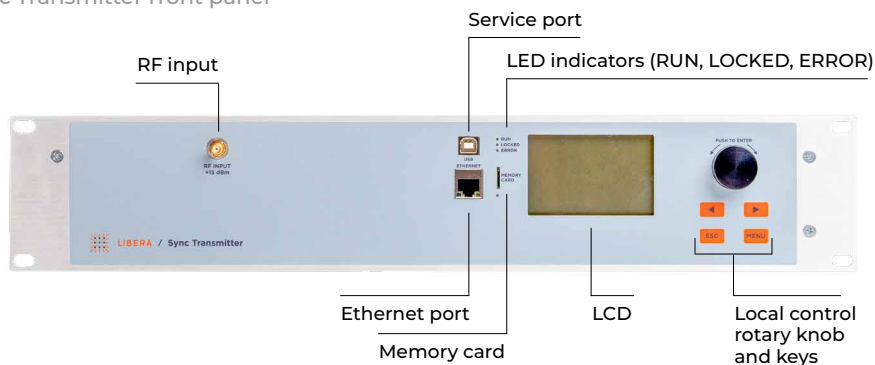

Figure 43: Libera Sync Receiver front panel

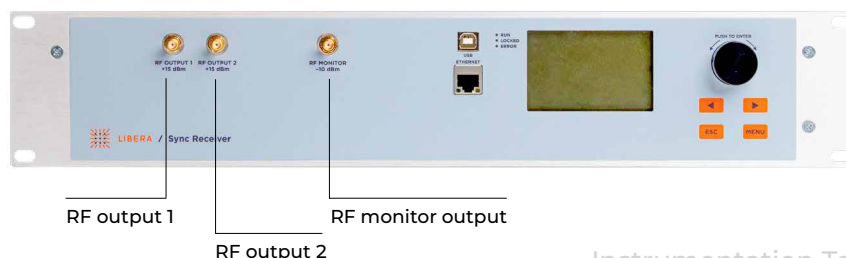

Figure 44: Libera Sync Transmitter and Receiver back panel

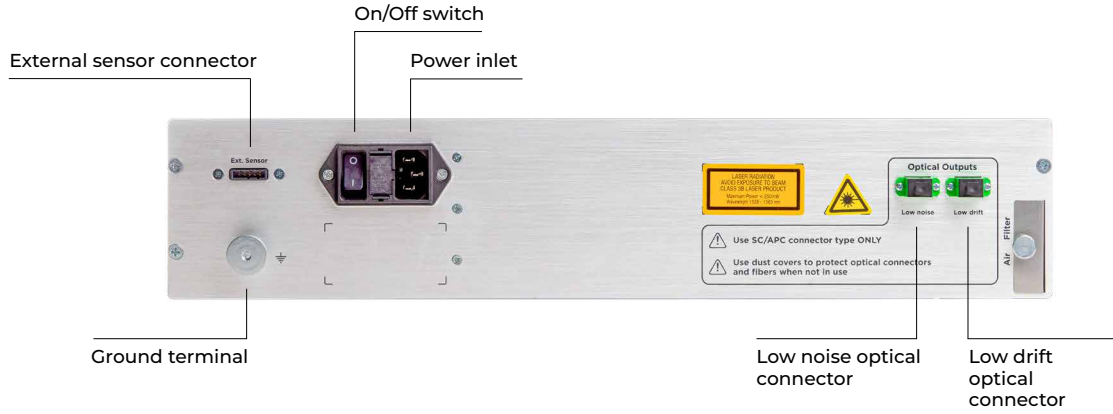

Figure 45: Libera Sync setup

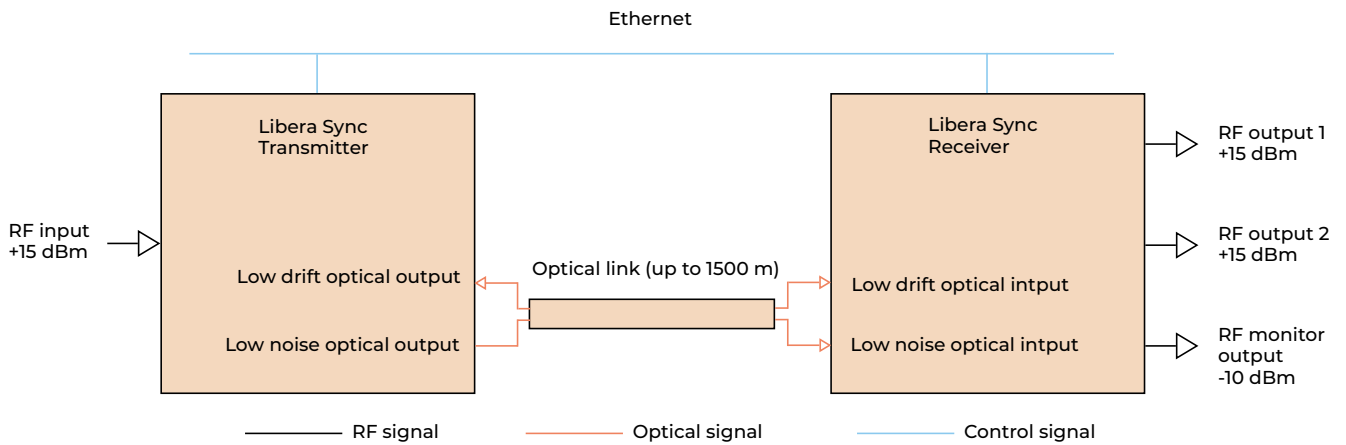

Table 12: Technical specifications of the Libera Sync

General product code	LSYN
Capabilities	
Carrier frequency *	2.6 GHz - 3 GHz
Added jitter (integrated from 10 Hz to 10 MHz)	<8 fs RMS
Long term drift (typical in 24 hours) Long term drift (typical in 16 hours)	<40 fs peak-to-peak <20 fs peak-to-peak
Optical link length	Up to 1500m, longer would require more stable environmental conditions along the link
Optical fiber drift compensation range	500 ps
RF input	1, SMA connector, 50 Ω
RF input power	+15 dBm ±1dB
RF outputs	2, SMA connectors, 50 Ω 1 monitor, SMA connector, 50 Ω
RF output powers	+15 dBm ±0.5 dB -10 dBm ±2 dB (monitor output)
Operating temperature range	20 - 28°C
Operating temperature stability	±1°C
Operating relative humidity range	0 - 80%
Operating relative humidity stability	±5 %
Dimensions	H: 2 U, W: 19" (rack mountable), D: 456 mm
* Custom frequencies are possible, e.g. 178.5 MHz , 500 MHz , etc. The performance parameters are deteriorated for frequencies below 2.6 GHz	

Functionalities
Fully automated start-up and tuning procedure
Remote and/or local control and monitoring
Local data logging on the memory card
EPICS IOC

ARCHITECTURE AND CONTROL SYSTEM INTEGRATION

All Libera instruments, regardless of the Hardware platform on which they are based, have a similar SW architecture. At the lowest levels, the Firmware and the FPGA code run in the dedicated Hardware modules and interface with the higher-level software through the libera-kernel layer.

The Software runs within the CPU of the instruments, where standard Linux distributions are used (e.g. Ubuntu, Rocky OS, etc.). Most of the Software is based on a general Software framework called Libera BASE, which on the lowest end provides hardware abstraction and interfaces to the Hardware components. The instrument-specific application is integrated within the Libera BASE framework that provides access to the application's configuration parameters, data buffers, and data streams. Finally, the Measurement and Control Interface (MCI) layer transfers parameters and data between the Libera application and various control system adapters, such as latest versions of EPICS, TANGO etc. (see Figure 46).

Figure 46: Software interfaces and building blocks within Libera instruments

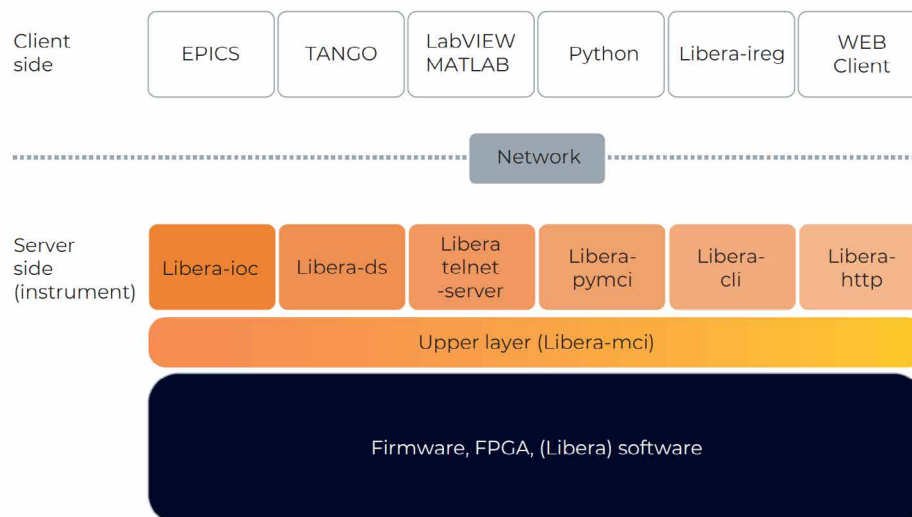

For most of the instruments, an EPICS-based Graphical User Interface is available to the user, providing access to all the instrument parameters and data. Depending on the GUI technology used, GUIs are currently available based on EDM panels, CSS, and Qt: see the examples in Figures 47 and 48. In the last years, for some instruments also a Web-server was introduced as well as a web-based GUI (see Figure 49).

If you are interested in accessing the FPGA and Software sources, please contact sales@i-tech.si.

Figure 47: Example of EDM GUI

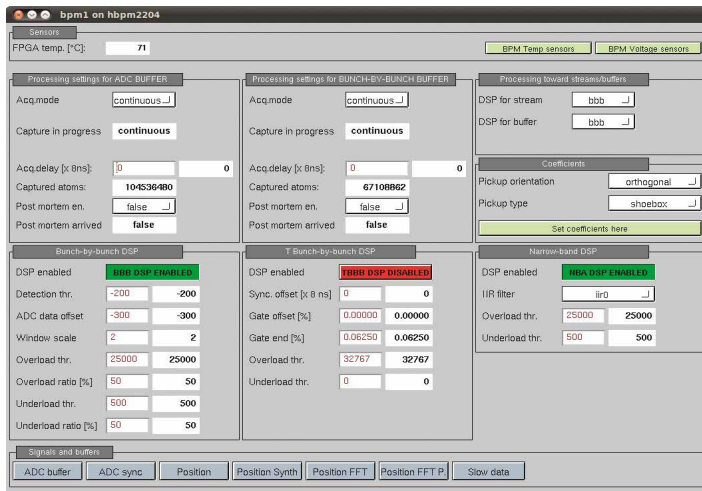

Figure 48: Example of CSS GUI

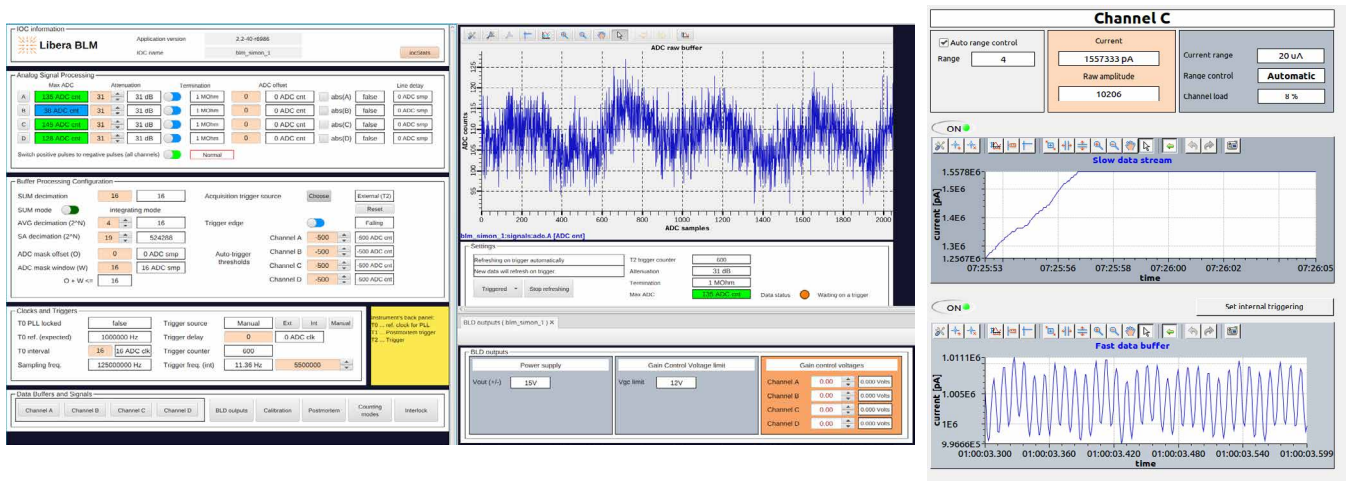
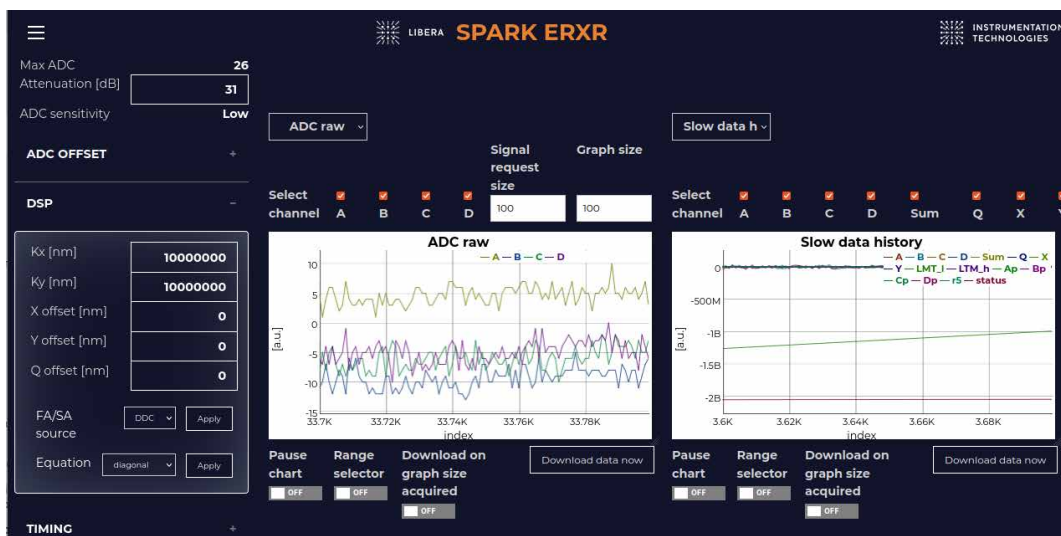

Figure 49: Example of a web based GUI



EXTENSIONS

Libera instruments can be integrated with other accelerators' subsystems by extending their functionalities using specific modules and custom-developed applications (refer to Table 13).

Table 13: Extensions options for Libera instruments

Interface	Description / example	Works with	Required module
Fast Orbit Feedback solution	Complete solution for electron machines that use Libera Brilliance+ and Libera Brilliance X instruments (Figure 50)	Libera Brilliance+ Libera Brilliance X	GDX module SER module Orbit Feedback application software Dedicated optical network Magnet correction data receiver* DAMC - UNIZUP module
	Complete solution for hadron machines that use Libera Hadron instruments (Figure 50)	Libera Hadron	GDX module SER 2 module COFB application software Dedicated optical network Magnet correction data receiver*
Real-time data streaming	Real-time data streaming directly from the FPGA through a dedicated instrument interface	Libera Brilliance+ Libera Single Pass E Libera Hadron Libera Single Pass H Libera Spark Libera Digit 500**	GDX module or GbE interface (depending on the instrument)
Interlock detection and output	Interlock detection and hardware interface towards Machine Protection System Compatible with Libera integrated platform instruments	Libera Spark Libera BLM	DAI module Interlock detection software
Additional Digital I/O channels	Add 2 extra digital I/O interfaces (LEMO) for communication and/or control of auxiliary components	Libera Spark Libera Digit 125 Libera Digit 500	DAI module I/O control software**
Analog outputs	Add an analog output to control an auxiliary component or transform a selected digital value (e.g. SUM, position, etc.) into a 16-bit analog value	Libera Spark Libera Digit 125 Libera Digit 500	DAI module DAC control software**
Serial interface	Add a RS-485 interface for half-duplex communication with auxiliary components Add multiple RS-485 interfaces for real-time data streaming towards magnet receivers	Libera Spark Libera Digit 125 Libera Digit 500	DAI module RS-485 control software**
Frequency down conversion	Convert the RF input signal to a lower frequency to match the input capabilities of a Libera instrument	Libera Spark EL Libera Single Pass E	Libera DWC

* Not provided by Instrumentation Technologies

** Basic control included only. Can be customized by users using source code

1 Orbit feedback solutions

Orbit feedback application is implemented in the GDX module which is compatible with Libera Brilliance+ and Libera Hadron instruments. Beam position data is exchanged via a dedicated network (daisy chain). Inside of every GDX module, corrections for magnet controllers are calculated in several matrix multiplication stages. Correction values can be applied locally (via the optional SER or SER 2 modules) or globally via optical or copper link.

Default implementation supports up to 256 BPM IDs and 128 magnet IDs, but can be extended, if required. Calculation rate is conditioned by the beam position data update rate (tested up to 30 kHz).

For testing and diagnostic purposes, synthetic waveform generation inside of the BPM electronics modules is supported.

Figure 50: Complete orbit feedback solution for electron/hadron machines

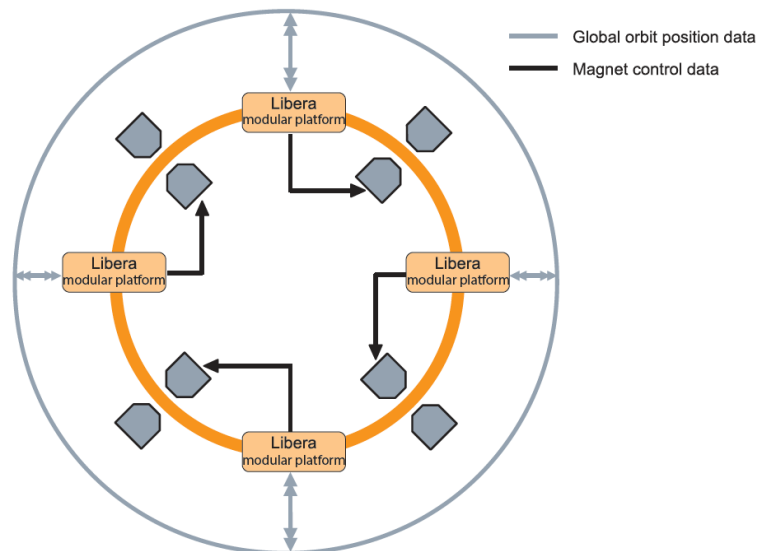

2 DAI module

The DAI module extends the interconnection capabilities of Libera instruments as shown in Table 14 (Applicable for Libera Spark, Libera Digit 125 and Libera Digit 500).

Figure 51: DAI module



Table 14: Technical specifications of the DAI module

General product code: MDAII.000.001	
Interface	Description
LEMO single (2x)	Single-ended LEMO, Input/Output configurable
LEMO differential (1x)	Differential LEMO, Interlock output (requires external circuit)
SMA (1x)	16-bit 100 kSps DAC output, 1 V at 50 Ohm
RJ-14 (1x)	Up to 20 Mbps, half-duplex

3 SER module

The SER module features four RS-485 interfaces directly controlled from the GDX module. The protocol and the baud rate are specified by the application in the GDX module (Table 15).

Figure 52: SER module



Table 15: Capabilities of the SER module

General product code: MSER1.000.001	
I/O interfaces	RJ-25, LVDS links to GDX
Baud rate*	Up to 2.5 Mbit/s
Protocol*	Asynchronous protocol EIA 485, byte per byte

* Specified by application in the GDX module

4 SER 2 module

The SER 2 module features eight RS-485 RJ-45 interfaces controlled via the PCI express link (Table 16).

Figure 53: SER 2 module



Table 16: Capabilities of the SER 2 module

General product code: MSER1.000.002	
I/O interfaces	RJ-45, PCI express link to AMC connector
Electrical	EIA 485
Protocol	High speed USI protocol

5 GDX module

The GDX module extends the interconnection capabilities of the BPM electronics. Four protocol independent small form pluggable (SFP) slots can be used to build a closed loop of all the instruments in the accelerator. It features a Virtex6 FPGA, which is completely open to user-developed applications. It can process the internal (within the chassis) and external position data at various data rates (Table 17).

Figure 54: GDX module



Table 17: Capabilities of the GDX module

General product code: MGDX1.000.001	
FPGA chip	Xilinx Virtex 6
Memory	2 GB DDR3
I/O interfaces	4x SFP+ compliant, multiprotocol operations, LVDS links to AMC connector
SFP protocol	AURORA, GbE, others on request; independent to each SFP
PCI express x4 bus interface to AMC connector	
On-board clock synthesizer and programmable VCXO for clock generation	
Board management is already established	

6 Libera DWC

The DWC-SP circuit is a four-port RF downconverter that can be used to down-convert the RF input signals from S-band to an intermediate frequency (Table 18).

Figure 55: Libera DWC



Table 18: Technical specifications of the Libera DWC module

	1 GHz	1.3 GHz	3 GHz
General product code	LDWC1.000.001	LDWC1.000.002	LDWC1.000.003
Supply voltage	6 V DC	6 V DC	6 V DC
RF input connector	SMA	SMA	SMA
RF input frequency	~1000 MHz	~1300 MHz	~3000 MHz
RF input power	Max 15 dBm	Max 15 dBm	Max 15 dBm
LO input connector	SMA	SMA	SMA
LO input frequency	Max 500 MHz	Max 900 MHz	Max 2800 MHz
LO input power	5 dBm	5 dBm	5 dBm
RF output connector	SMA	SMA	SMA
RF output frequency	<600 MHz	<600 MHz	<600 MHz

7 Libera Amplifier 110

The Libera Amplifier 110 is a four-channel, low noise, non inverting measurement amplifier. Its gain can be set in increments of 10 dB from -50 dB to 60 dB via an SPI control interface (Figure 56).

The Libera Amplifier 110 is intended to reduce wide dynamic ranges in order to enable further signal processing and acquisition. An example of an application is pickup signals in beam position monitoring in accelerators, where the Libera Amplifier 110 can be used in combination with Libera Hadron.

Figure 56: Libera Amplifier 110 front and back panel

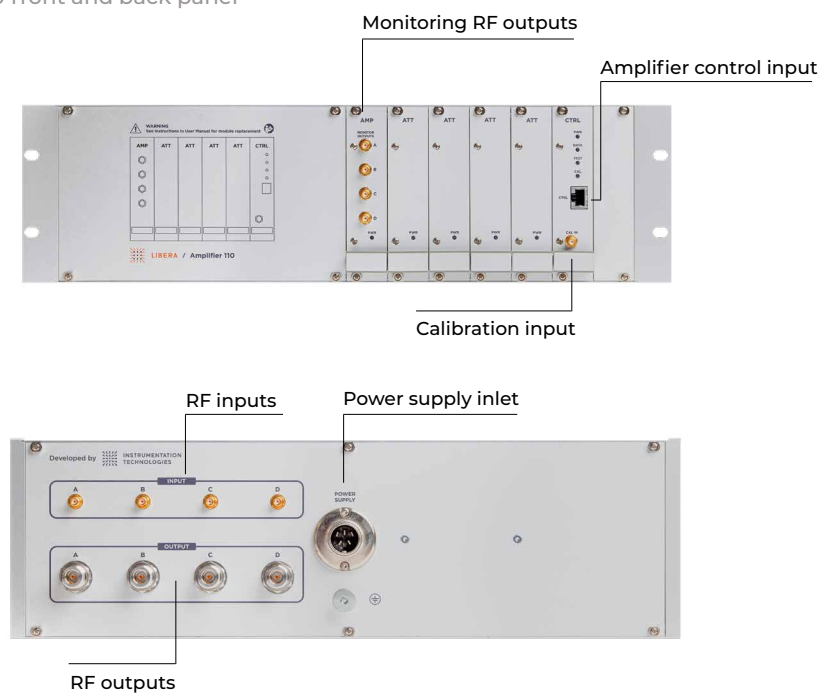

Table 19: Technical specifications of the Libera Amplifier 110

General product code: LAMP	
Dynamic range	From -50 dB to 60 dB
Input voltage	Max. 230 V peak (max. average input power 1.5 W per channel)
Output voltage	± 2 V peak
Bandwidth	From 40 kHz to 55 MHz
Gain error between channels	Max. ± 0.1 dB
Output referred added noise	<15 mVrms, for gain 60 dB <5 mVrms, for gains <60 dB
Input and output impedance	50 Ω

8 Libera BPM AMP



More

The BPM RF amplifier is designed to increase the amplitude of RF signals generated by the beam position monitor pickup electrodes prior to signal processing by the BPM electronics. The amplifier provides precise, low-noise, and stable gain to ensure optimal signal integrity. This enhances the accuracy, resolution, and overall reliability of beam position measurements, particularly under low beam charge operating conditions.

Two amplifier variants are available to accommodate different beam operation modes:

- CW Version – Optimized for continuous-wave (CW) beam operation as well as beams structured in macropulses.
- Pulsed Version – Optimized for single-bunch beams and other single-pulse operating modes. The pulsed version incorporates integrated bandpass filtering, optimized for short-duration pulsed signals.

Figure 57: Libera BPM AMP front and back panel

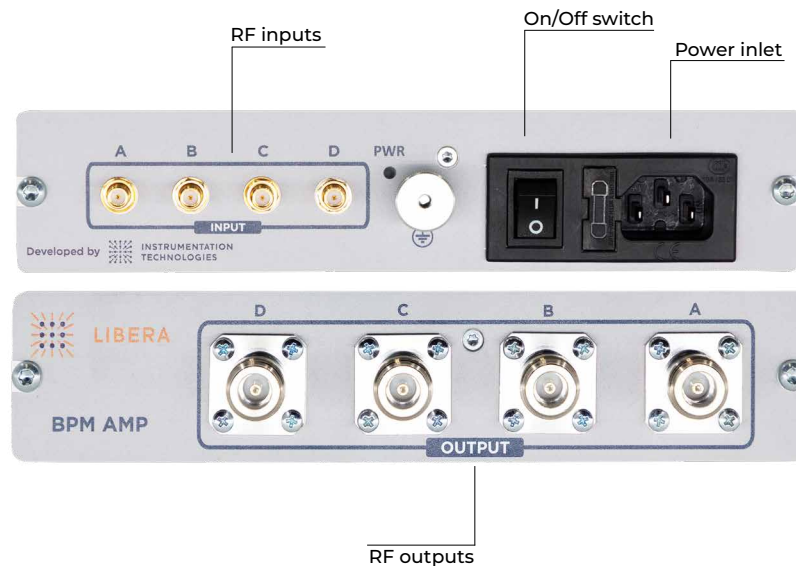

Table 20: Technical specifications of Libera BPM AMP

	CW version	Pulsed version
General product code:	LAMB	LAMB
Gain	~25 dB	~16.5 dB
P1dB	17 dBm	13 dBm
Bandwidth	< 850 MHz	494.5 MHz – 504.1 MHz
NF	< 3.4 dB @ 750 MHz	< 7.5 dB @ 500 MHz
Power consumption	12 VA	
Supply voltage	85-264 VAC, 47-63 Hz	
Dimensions	43.8 x 210 x 173 mm	
Weight	1.65 kg	

9 Libera Pilot Tone FE



The Libera Pilot Tone FE is an analog front-end installed in the tunnel and connected between the BPM pickup and BPM electronics. It combines the RF BPM signals with a pilot tone signal that is slightly offset to the RF. Both signals pass through the RF cables to the BPM electronics and are exposed to the same disturbances.

The Libera Pilot Tone FE is the result of a partnership between Elettra Sincrotrone Trieste and Instrumentation Technologies.

Figure 58: Libera Pilot Tone FE front and back panel

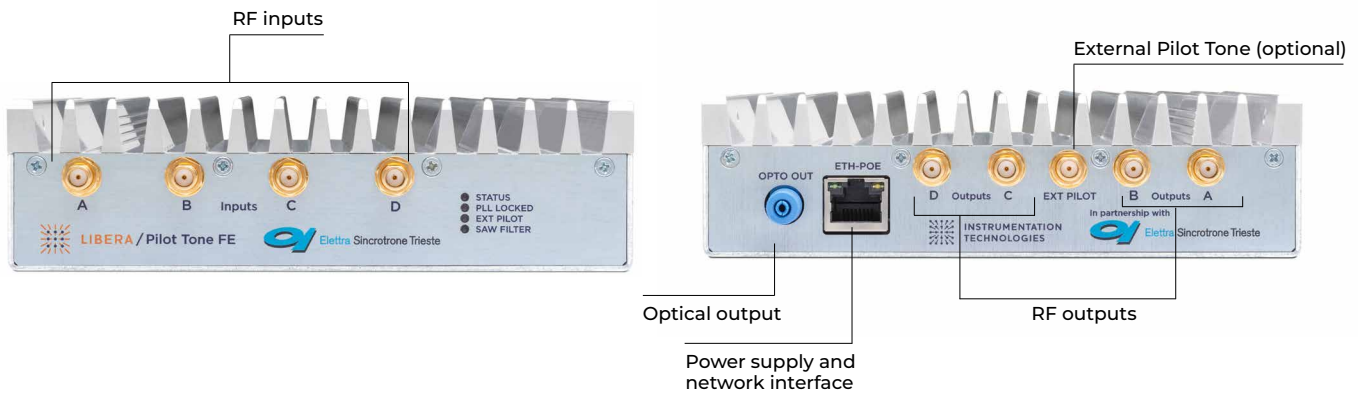
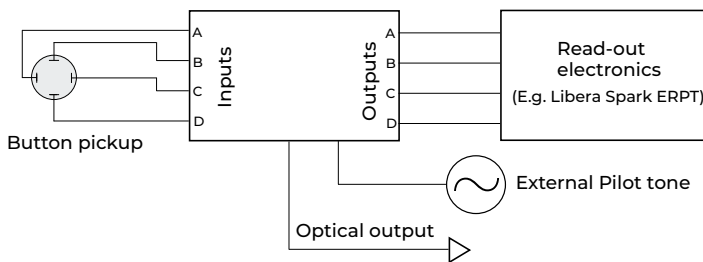

Figure 59: Example setup of the Libera Pilot Tone FE in combination with Libera Spark ERPT



Most common RF frequencies are supported: 352 MHz, 408 MHz and 500 MHz. The Libera Pilot Tone FE is powered and controlled through a PoE RJ-45 interface via TCP-IP. Important parameter settings are confirmed through an optical interface.

Such BPM system ensures stable position readout with long-term stability $<1 \mu\text{m}$.

Table 21: Technical specifications of the Libera Pilot Tone FE

General product code: LPTF	
Frequency versions	500 MHz 408 MHz 352 MHz
Input/Output channels	4 / 4 (SMA-F connectors)
Input impedance	50 Ohm
Programmable attenuation	0 to 90 dB
1 dB compression point	+16 dBm
Crosstalk	Better than -60 dB
Pilot tone generation	Internal or external (SMA-F input)
Control interface	TCP-IP over Ethernet
Power supply	PoE or 9-12 V, 1 A
Dimensions	175 x 151 x 40 mm
Weight	1,2 kg
Temperature dependence	Frequency dependence: Approximately -250 Hz/°C Amplitude dependence: Approximately -0.03 dB/°C

10 Libera XBS FE

Libera XBS FE is a supplementary analog front-end for the Libera Brilliance+ and Libera Brilliance X BPM electronics, to be used in combination with the 3rd generation BPM module and Libera 2BPMRTM. The Libera XBS FE contains a cross-bar switch matrix, similar to the one used in the standard Libera Brilliance+ BPM modules, and is intended to be installed in the tunnel, as close as possible to the BPM pickup.

The advantage of switching the RF signals already in the tunnel, is the possibility to compensate the long-term drifts that are induced on the long RF cables, in addition to the ones in the electronics.

The system of Libera XBS FE and Libera Brilliance+ or Libera Brilliance X ensures a stable position readout with RF cables as long as 200 meters.

Figure 60: Connection scheme of Libera XBS FE and the 3rd generation BPM module in Libera Brilliance+ (or Libera 2BPMRTM module)

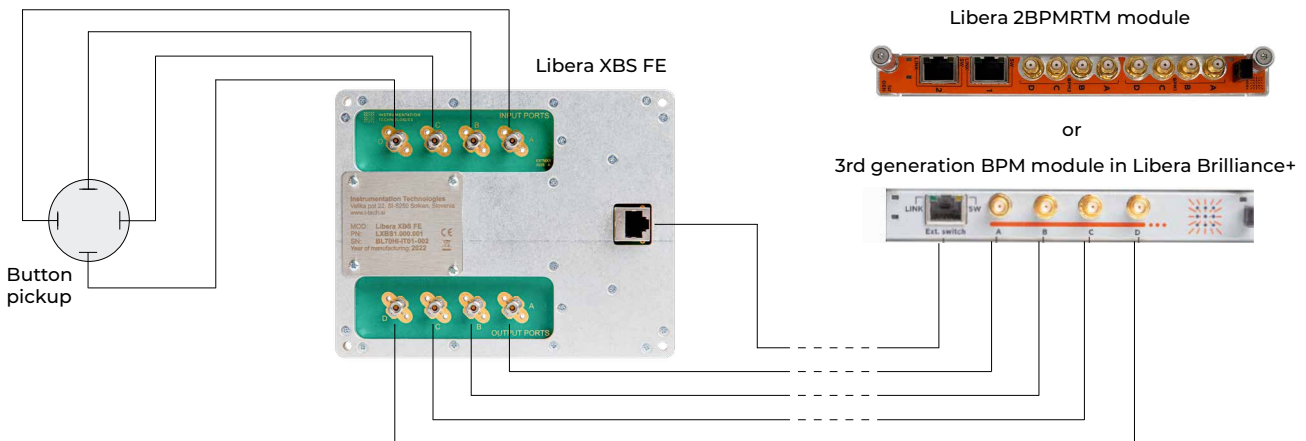

The Libera XBS FE supports all standard synchrotron RF frequencies. It is powered and controlled by the 3rd generation BPM module through a standard Cat.7 cable and RJ-45 interface. The switching frequency is configurable by the digital control in the Libera Brilliance+ and is fully synchronized with the Digital Signal Conditioning that calculates the calibration coefficients.

Table 22: Technical specifications of the Libera XBS FE

General product code: LXBS1.000.001	
Frequency range	350 MHz to 510 MHz
Input/Output channels	4/4 (SMA-F connectors)
Maximum input signal range	+4 dBm CW
Maximum distance to the BPM module	200 meters (tested)
Power supply and control cable	Cat.7 S/FTP
Temperature dependence	<200 nm/K
Dimensions	173 x 129 x 19 mm
Weight	~0.8 kg

LIBERA VIVA

LONG-TERM SUPPORT & SERVICES

Every Libera instrument is delivered with a standard warranty, ensuring compliance with the agreed specifications and freedom from manufacturing and software defects.

To ensure long-term support beyond the standard warranty period we offer Libera VIVA, a flexible service program designed to keep your instruments up to date while ensuring predictable maintenance costs and minimized downtime.

For customers who wish to extend their coverage, Libera VIVA may be activated after the expiration of the standard warranty and customized to specific operational need.

Libera VIVA offers the following program options:

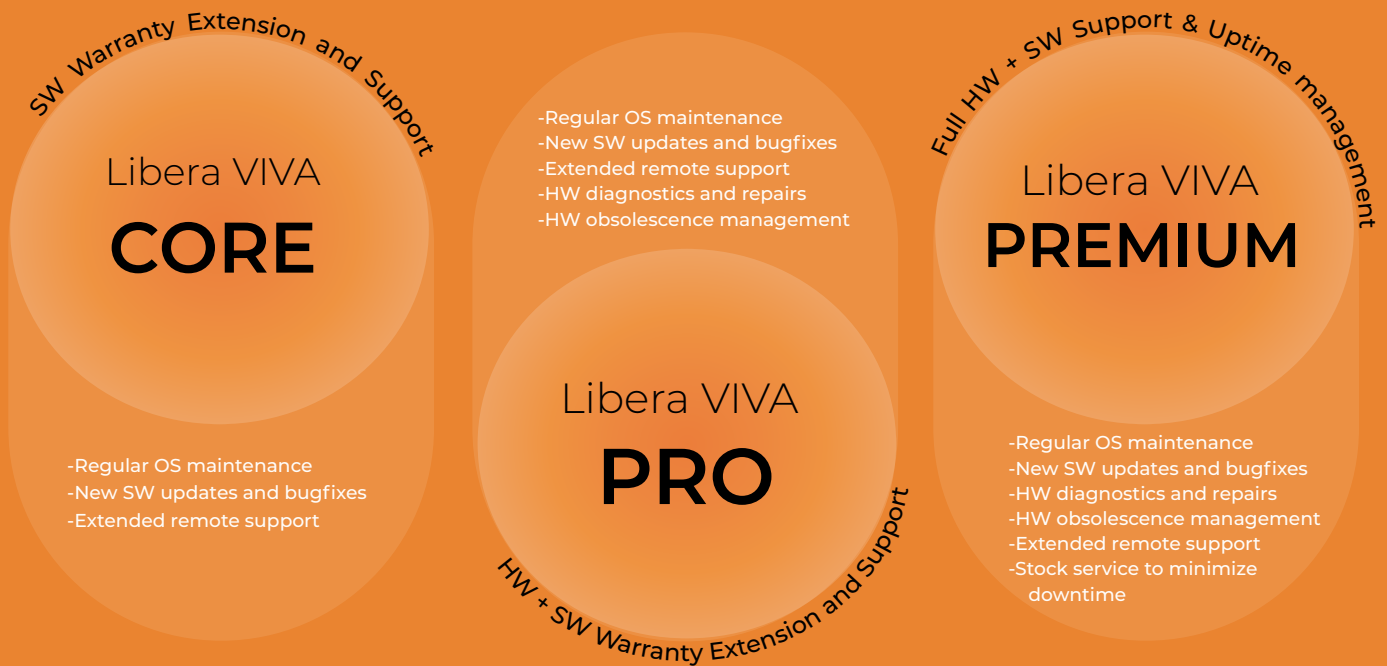

Additional services can be integrated into a Libera VIVA program or discussed separately as standalone options:

SECURITY UPDATE PROGRAMS

Customized solutions designed to proactively address software vulnerabilities and strengthen the cybersecurity of Libera instruments.

ON-SITE ASSISTANCE

Professional support provided during the installation, commissioning, and integration of Libera instruments into your control system, ensuring smooth setup and operation.

Contact our team to explore more about Libera VIVA programs and other services.

Get in touch

HQ

Instrumentation Technologies d.o.o.

Address

Velika pot 22
SI-5250 Solkan
Slovenia

Web

i-tech.si

Contacts

P: +386 5 33 52 600

E: info@i-tech.si

Customer support

E: support@i-tech.si

Sales/Marketing

E: sales@i-tech.si

Contact our local representatives in:

- China
- India
- Japan
- Korea
- US



REFLEX

WHERE IDEAS MEET TECHNOLOGY



LIBERA



INSTRUMENTATION
TECHNOLOGIES

CONTACT US AT

info@i-tech.si
www.i-tech.si