



The FAIR pLINAC RF Systems

Libera Workshop
Sep. 2011

Gerald Schreiber

- (1) Overview GSI / FAIR
- (2) FAIR Proton Linear Accelerator "pLinac"
- (3) pLinac RF Systems
- (4) First experience with the Libera LLRF
- (5) pLinac Klystron- and Cavity Test Stand at GSI
- (6) Conclusion



Overview – GSI / FAIR:

Existing GSI Facility



GSI - Helmholtzzentrum für Schwerionenforschung mbH

Heavy Ion Accelerator Facility



GSI general

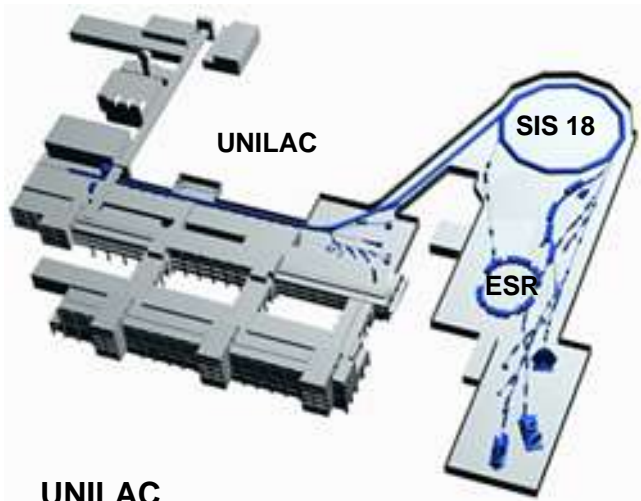

UNILAC

a 120 meter long linear accelerator,
 2 – 11.4 MeV/u

SIS 18

217m circumference,
 up to 2 GeV/u

ESR

accelerated ions, whether stable or
 radioactive can be stored up to several
 hours

Phelix / Nhelix

High energy lasers

Foundation	1969
Associates	Federal Republic of Germany (90%), State of Hessen (10%)
Member	Helmholtz Association
Task	Construction and operation of accelerator facilities and research of heavy accelerated ions in the range from He to U.
Staff	~1100 employees, including 600 scientists and engineers
Capital equipment	Linear accelerator UNILAC Heavy ion synchrotron SIS Experiment storage ring ESR Fragment separator FRS High-energy/high-efficiency laser PHELIX (being constructed) Several large systems of spectrometers and detectors Medical irradiation unit for cancer therapy
Scientific Cooperation	Users of the GSI facilities are predominantly non-resident scientists, mainly from German Universities (totalling over 1,000 scientists per year). World-wide cooperation with approximately 400 institutes from over 50 countries.



Overview – GSI / FAIR:

FAIR – Facility for Antiproton- and Ion Research

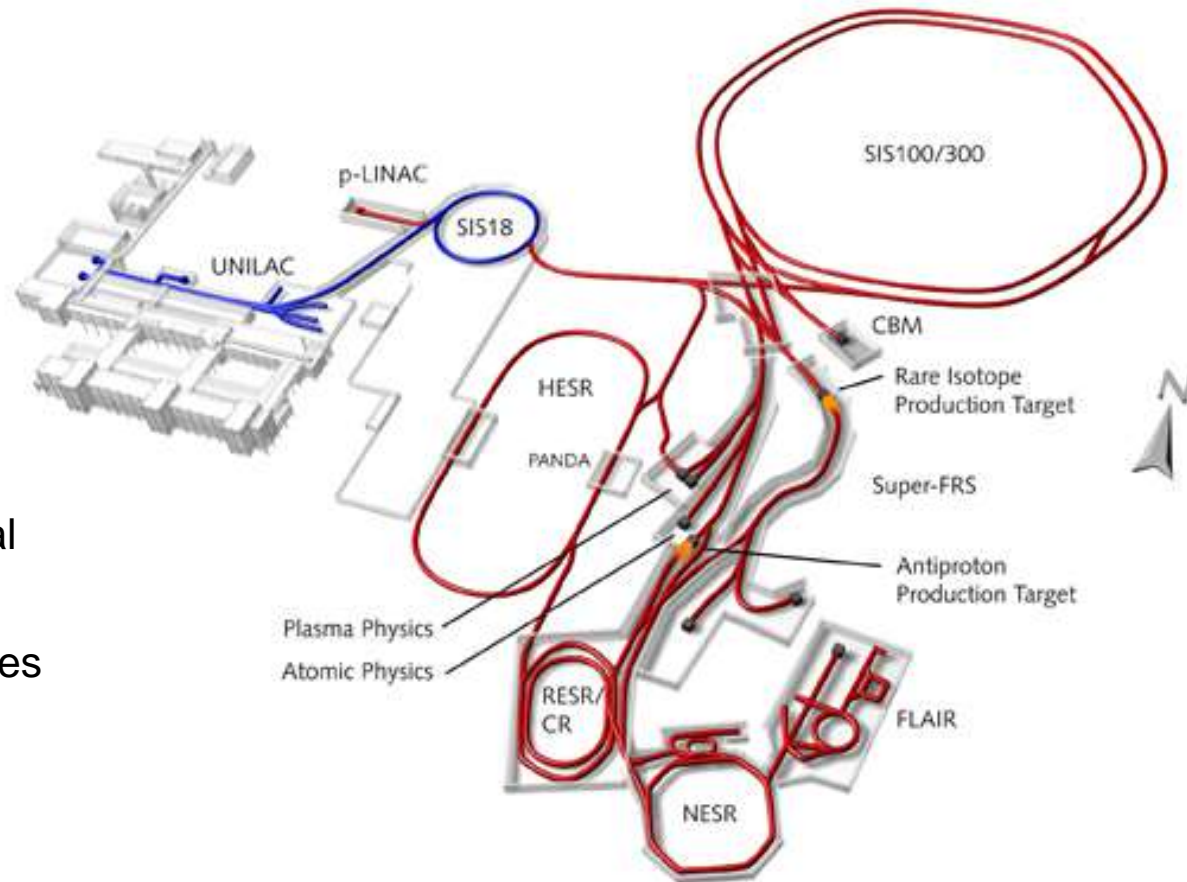

8th of Nov. 2007: Official Project Start

16 FAIR Partner countries

More than 40 countries involved



Overview – GSI / FAIR:
FAIR





Overview – GSI / FAIR:
Libera @ FAIR



currently planned Libera applications at GSI and FAIR:

pLinac:	10 x LLRF xx Pickups(for BPM and TOF) 118 MSa/s "undersampling"
SIS18:	12 BPMs
SIS100:	84 BPMs
CR:	18 BPMs
HEBT:	40 BPMs
...	...

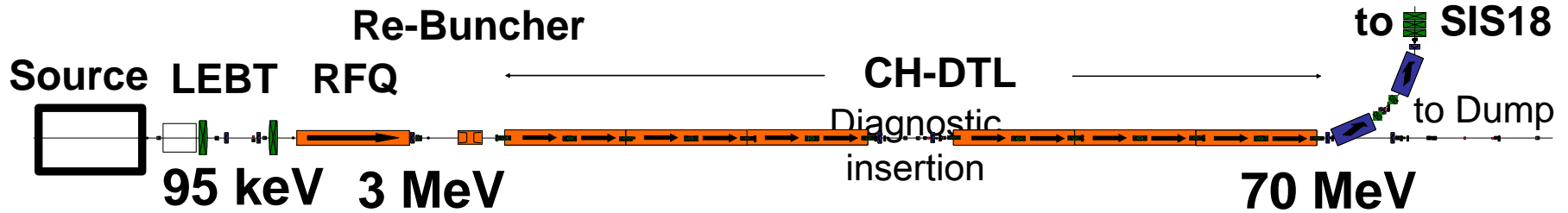

- ECR proton source & LEPT
- RFQ
 - Klystron
- 3 re-bunchers
 - Solid State Amplifiers, 45 kW
- 6 accelerating cavities
 - 6 Klystrons (2.5 MW)
- 2 dipoles, 45 quadrupoles, 7 steerers
- 10 turbo pumps, 34 ion pumps, 9 sector valves
- 41 beam diagnostic devices

10 RF Systems

Beam energy	70 MeV
Beam current (op.)	35 mA
<i>Beam current (des.)</i>	<i>70 mA</i>
Beam pulse length	36 μ s
Repetition rate	5 Hz
RF-frequency	325.224 MHz
Tot. hor emit (norm.)	2.1 / <u>4.2</u> μ m
Tot. mom. spread	$\leq \pm 10^{-3}$
Linac length	≈ 35 m

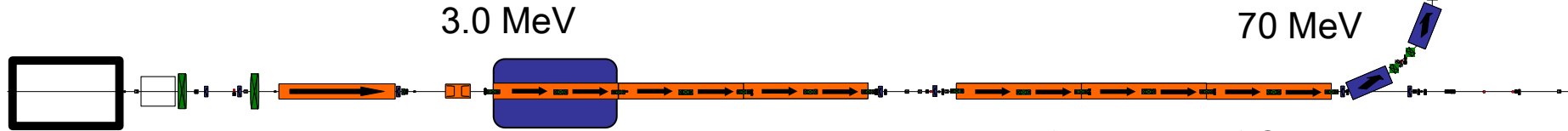

Rf-coupling of CH-cavities:

- reduced number of klystrons
- reduced space requirements
- avoid rf-power line splitting / high power phase shifters
- reduce cost for rf-equipment

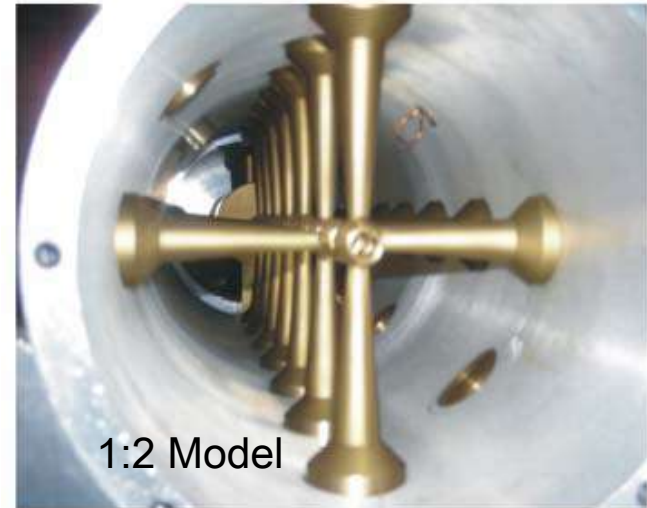
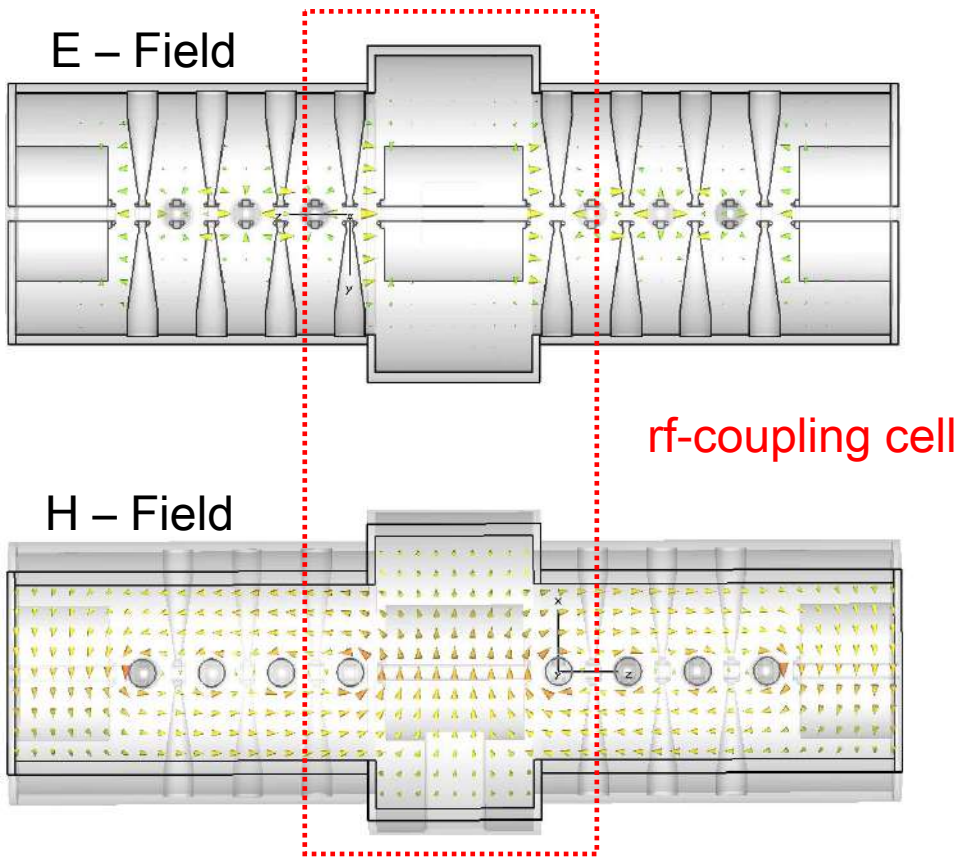

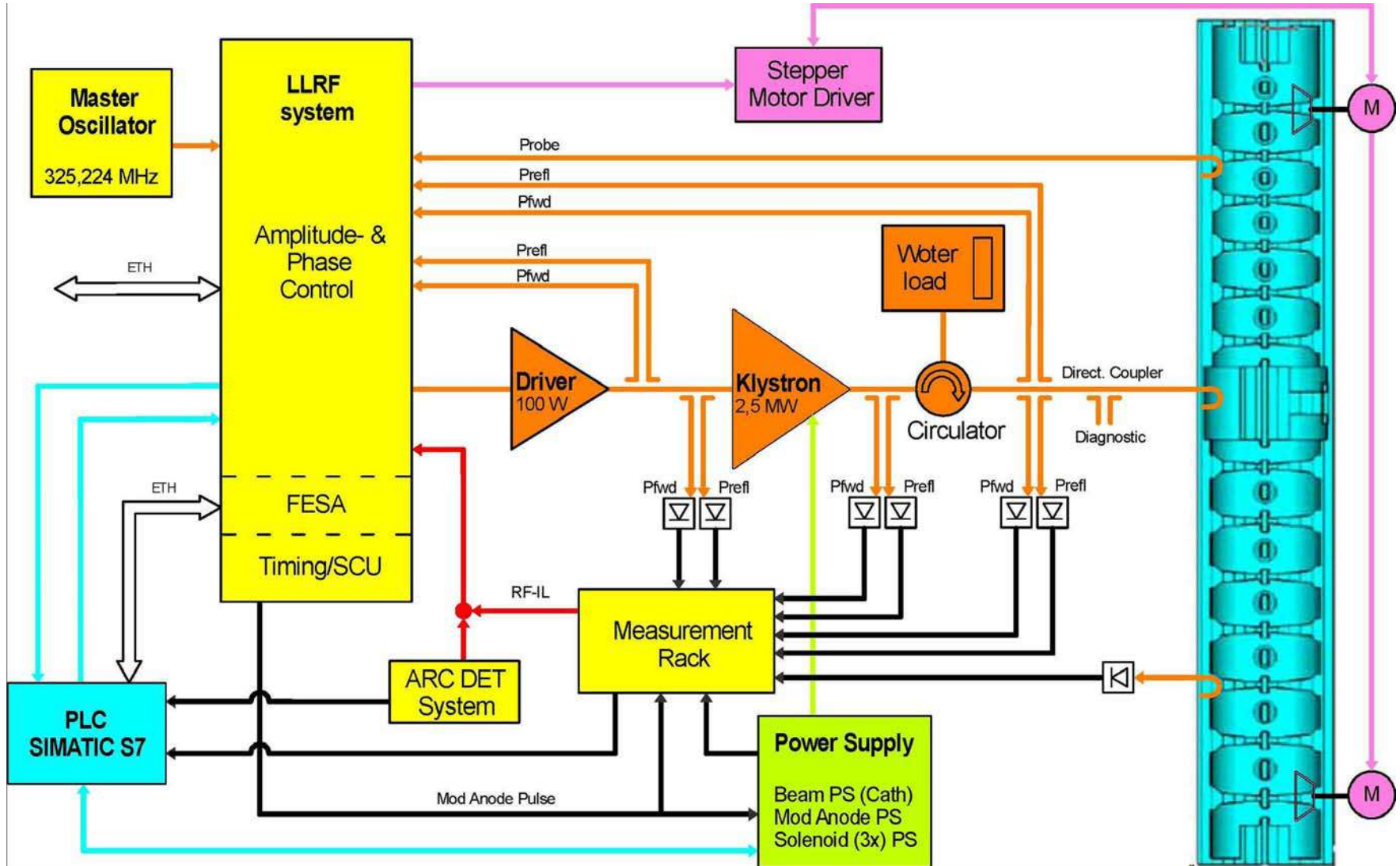

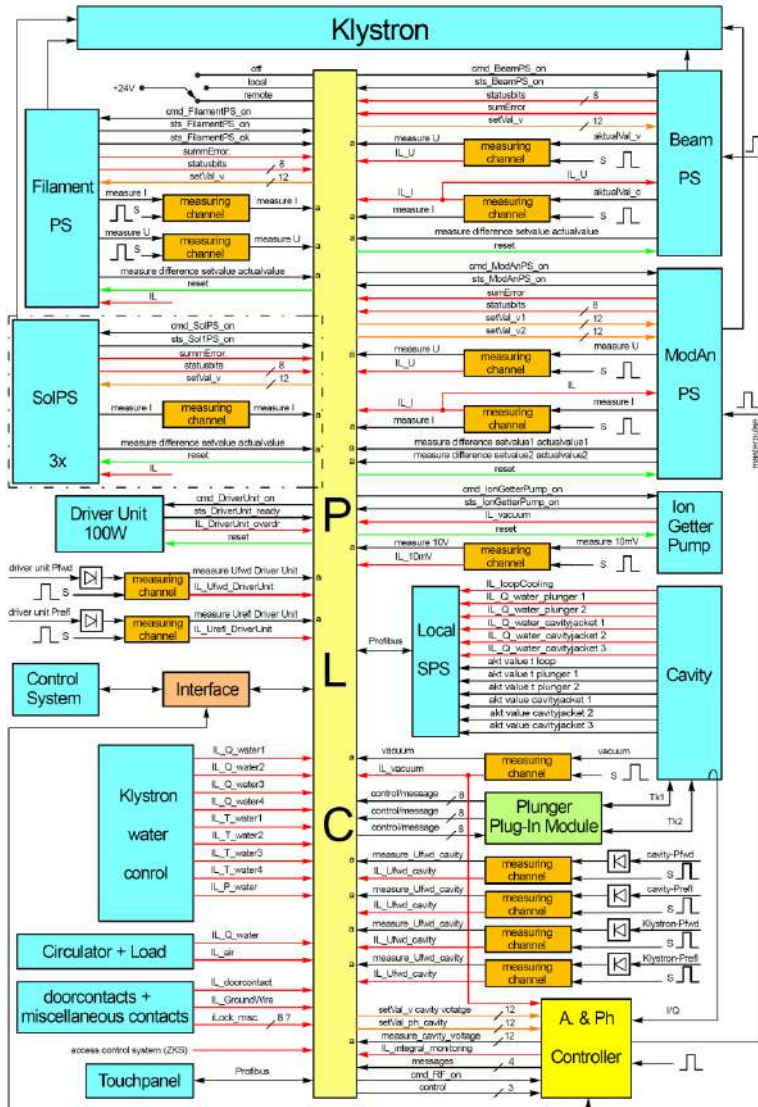

Measurement + Fast Interlock rack for

- data acquisition by sample&hold during the RF pulse
- fast interlock generation by adjustable thresholds
- output of sampled values for the PLC and analog instruments
- monitoring of RF signals by oscilloscope and fast sampling cards

PLC (SIEMENS S7-400) for

- visualization of sampled values (power, ps voltages etc.)
- visualization of slow signals (cooling water flow, temperatures etc.)
- controlling the power up/down sequence of all components
- slow interlock handling
- status reporting to the FAIR central control system



pLinac RF Systems:

Requirements for the LLRF



- 325.224 MHz
- Up to 5 Hz, 70 to 200 us RF pulse length (safety margin incl.)
- Heavy beamload expected, (1.2 -> 2.5 MW)
- Triggers for external devices (Klystron Power Supplies, Fast Interlock Rack, etc...)
- Fast interlock inputs (arc detection system, klystron safety, personal safety...)
- Local operation mode, local GUI for “RF experts”
- Accuracy: 0.1% in amplitude and 0.5° in phase (max!)
- Control system integration, Timing

Timing Interface
 GSI and CERN
 development,
 deterministic Ethernet-
 based field bus :
White Rabbit



FAIR Central Control
 System Interface:
 FRONT-END
 SOFTWARE
 ARCHITECTURE:
FESA

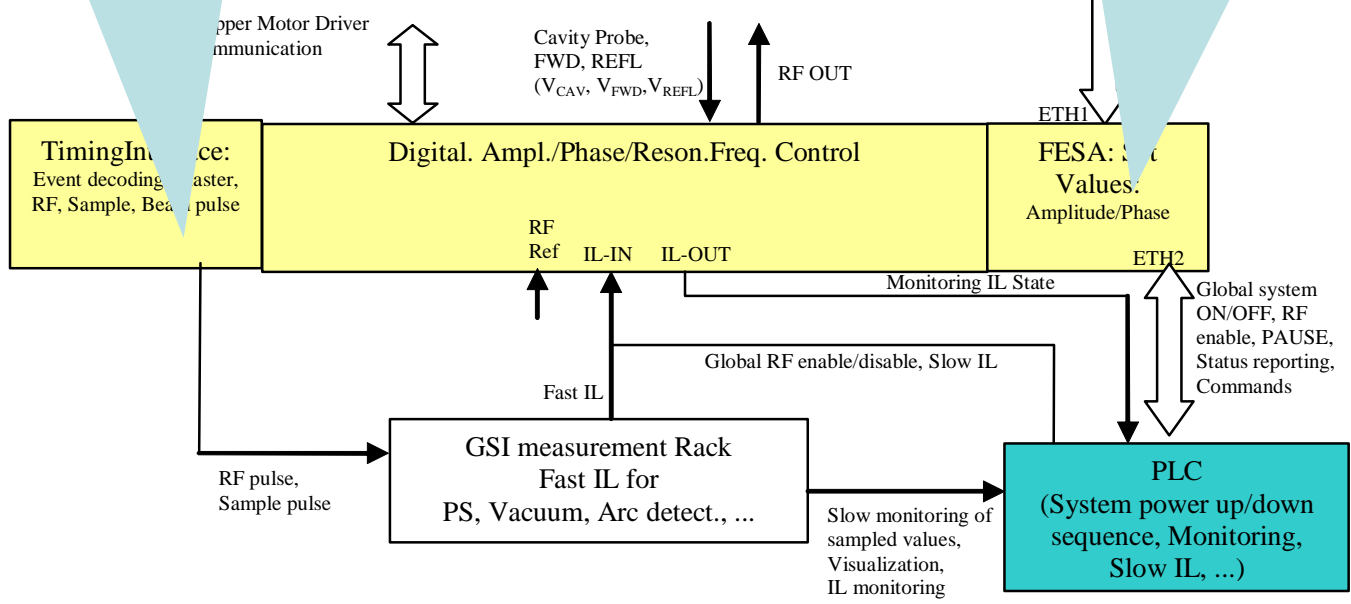

LLRF Tests at GSI (Linac-HF):

Old RF test cavity tuned on 325.224 MHz (fixed)

325.224 MHz reference oscillator

Libera LLRF controller

100 W power amplifier

RF Mixer for beam loading simulation

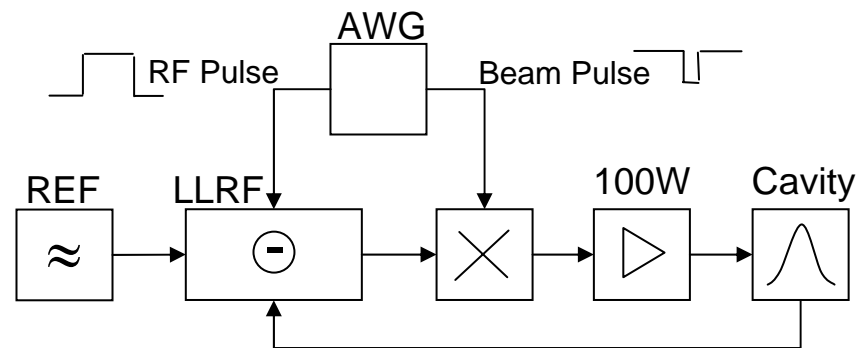

Laboratory conditions for the first tests with the Libera LLRF:

- Rectangular RF pulse (set value), no "preshaping"
- Only rough optimization of PI control parameters
- Reference oscillator phase noise: $< -105\text{dB/Hz}$ ($\text{df}=20\text{kHz}$) ☹
- Beam loading "by mixer" not optimal
- no feed-forward implemented yet

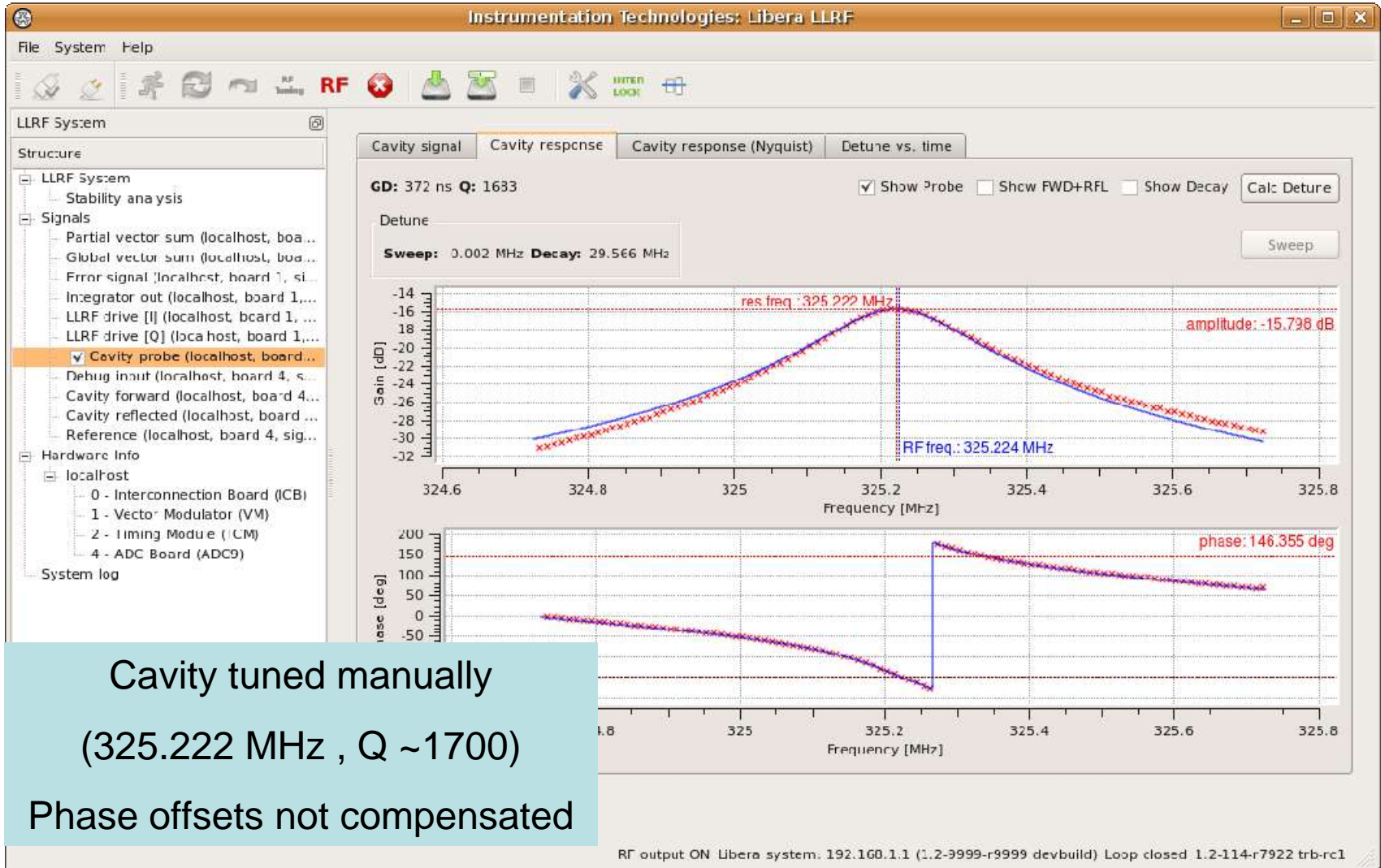

Cavity tuned manually
(325.222 MHz , Q ~1700)
Phase offsets not compensated

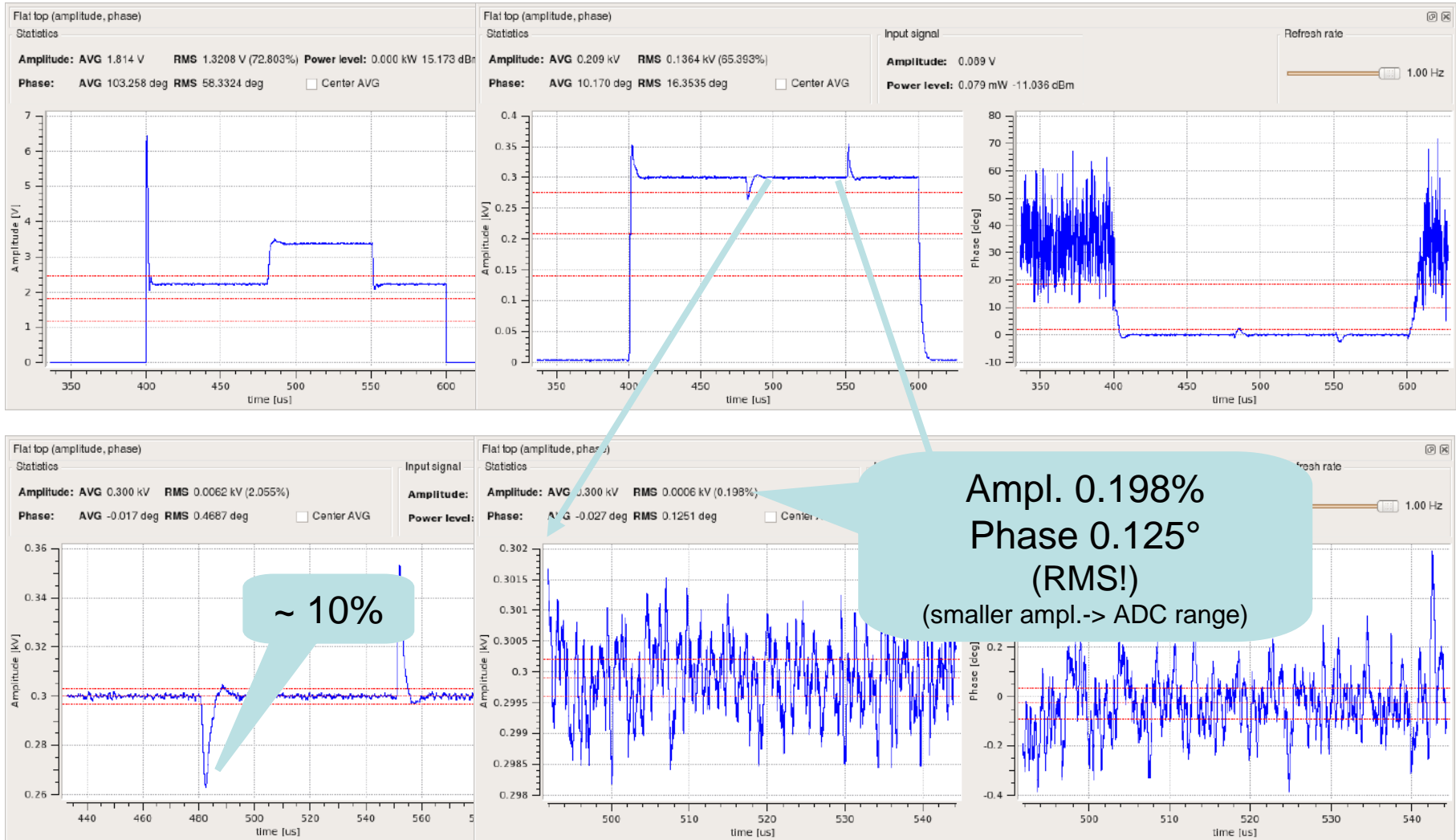

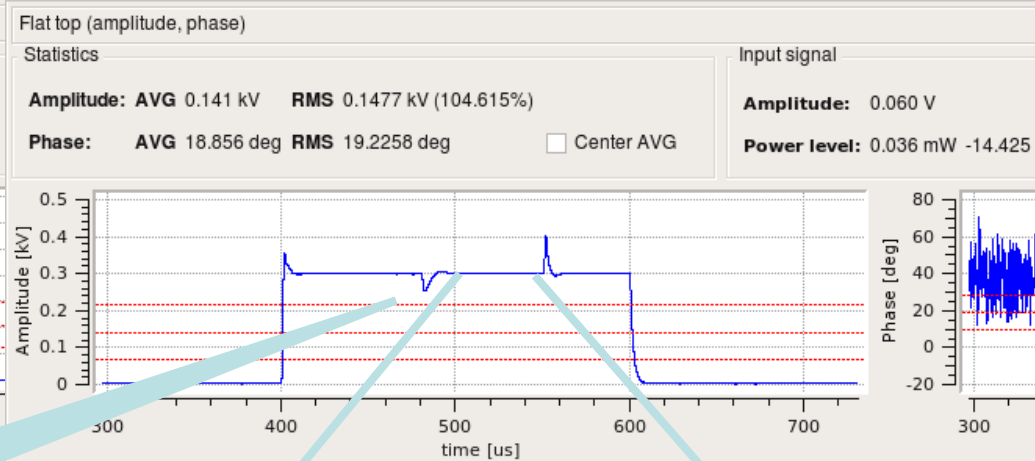
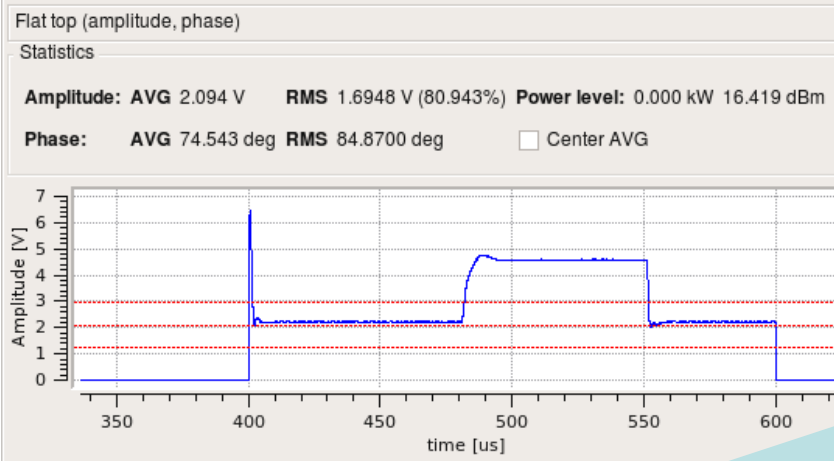

Ampl. drop: ~ 20%

Ampl. 0.18 %
Phase 0.12 °

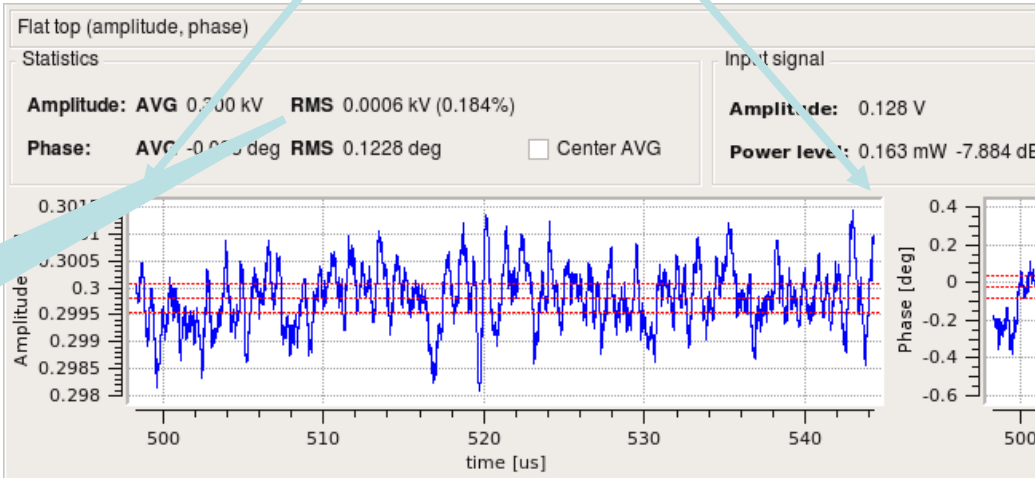

Planned RF test bench for the klystrons and the pLinac cavities:

- Klystron already available (Toshiba E3740GSI)
- Power supplies by Transtechnik (ready March 2012)
- Low-level-RF ordered (feed forward and feedback): Instrumentation Technologies
- Circulator, RF load and waveguides from commercial manufacturers
- Driver amplifier from "RES Ingenium / Italy" (already delivered and tested)
- Delivery of first CH cavity: Dec. 2011
- RF operation at test stand: June 2012

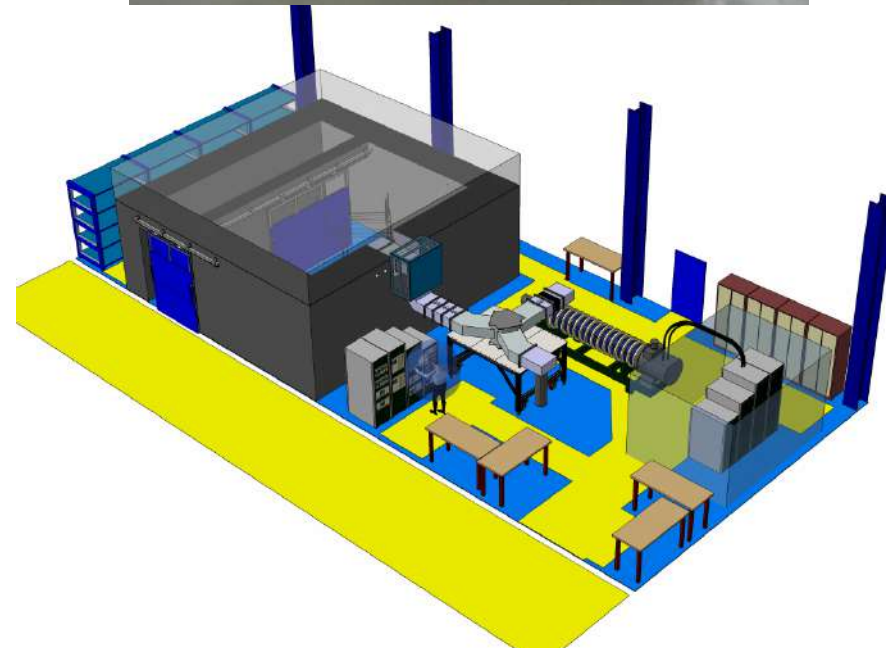

- The FAIR pLinac plannings are in progress, building construction starts in 2012, pLinac ready for commissioning: 2017
- A dedicated RF test stand is under construction for klystron- and cavity tests, first RF tests mid of 2012
- pLinac LLRF control loops: slovenian inkind contribution
- first experience with the Libera LLRF test system
 - Even with further optimizations (PI parameters, experimental setup, ...) an LLRF feed-forward implementation for the beam loading compensation is recommended!
 - Pulse pre-shaping is needed
 - Linearization of klystron gain (?)