

# Commissioning of on-ramp closed orbit feedback system for hadron synchrotron SIS18

Libera workshop 2020



Sajjad Hussain Mirza  
(s.h.mirza@gsi.de)

Rahul Singh  
(r.singh@gsi.de)

Beam Instrumentation GSI  
Darmstadt, Germany



# Outline

- ❖ GSI and FAIR
- ❖ Introduction to the closed orbit feedback system
- ❖ Robustness requirements for on-ramp orbit correction in SIS18
- ❖ Important investigations regarding on-ramp model drift
- ❖ Verification of theoretical conclusions at the functional COFB of COSY Jülich
- ❖ Hardware description for SIS18 COFB
- ❖ Experimental results:
  - Measurement of the spatial model mismatch over ramp
  - Measurement of the temporal system identification
  - Orbit correction and manipulation
  - Experimental demonstration of model mismatch based-COFB instability.
- ❖ Summary

# FAIR: An extension of GSI

(under construction)



## Main purpose:

- High intensity pulsed ion beams from proton to Uranium

## Extra requirements to SIS18:

- More control on beam quality to deliver more intensity to SIS100 (**closed orbit care**)

# Closed orbit perturbations

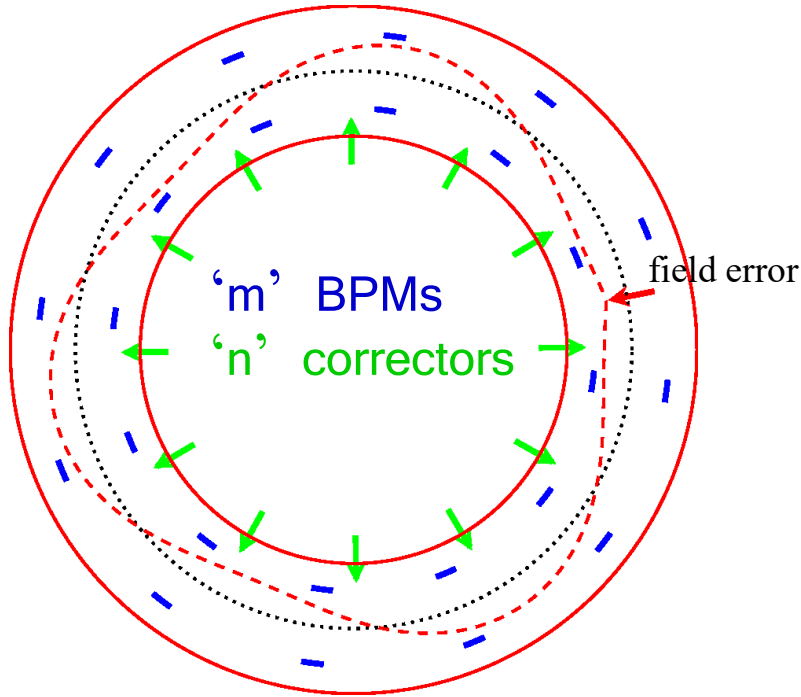

Schematic of the SIS18 perturbed orbit

closed orbit  $w_c(s)$  field error  $\theta_i$

$$w_c(s) = \sum_{i=1}^N \theta_i \frac{\sqrt{\beta(s_i)\beta(s)}}{2\sin(\pi Q_z)} \cos(|\mu(s) - \mu_i| - \pi Q_z)$$

- field error  $\theta_i$ : mrad
- closed orbit  $w_c$ : mm
- $\beta$ : beta function
- $\mu$ : phase advance
- $Q_z$ : coherent tune in either transverse plane

$$[W]_{m \times 1} = [R]_{m \times n} [\theta]_{n \times 1}$$

As long as the machine settings remain constant, ORM is fixed usually referred to as spatial model

# Closed orbit perturbations in SIS18

At injection

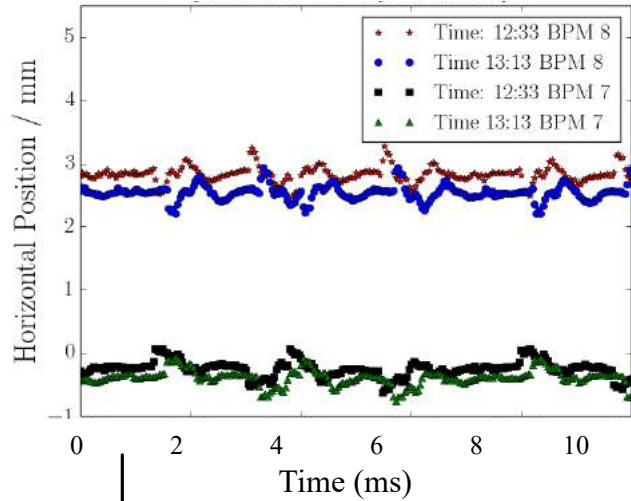

Fourier Transform

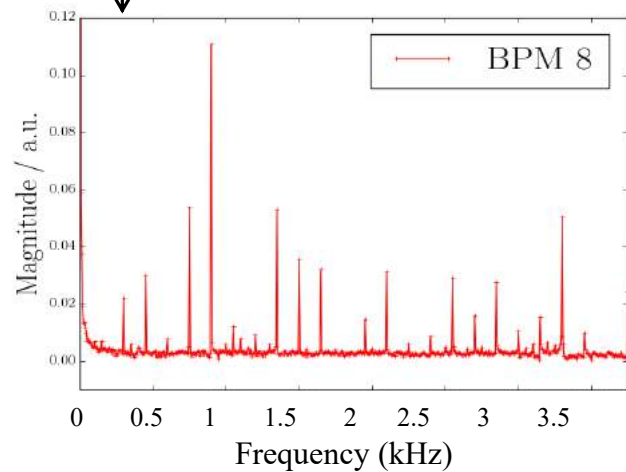

During ramp

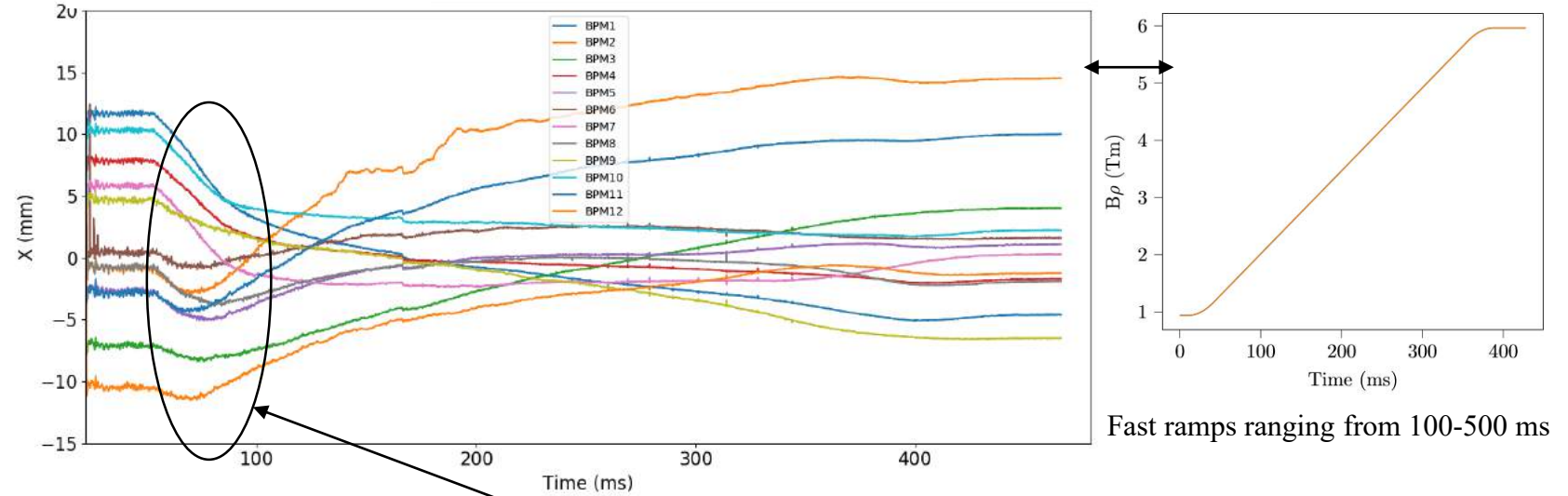

Ramps of two cycles

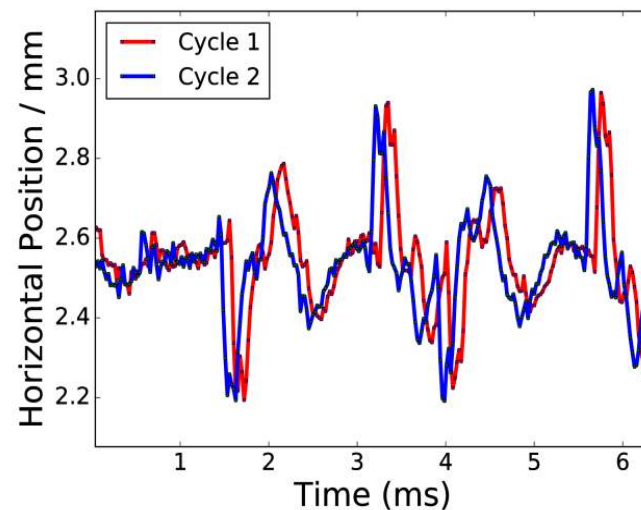

No damping at higher energies for hadrons  
contrary to light sources

The mismatch between beam energy and dipole field is not actively corrected in SIS18 so a dispersion induced orbit shift is observed during the ramp

$$x_D = D_x \frac{\Delta p}{p}$$

A closed orbit feedback system with bandwidth of several 100 Hz and robust to on-ramp model mismatch was planned

# Closed orbit feedback system

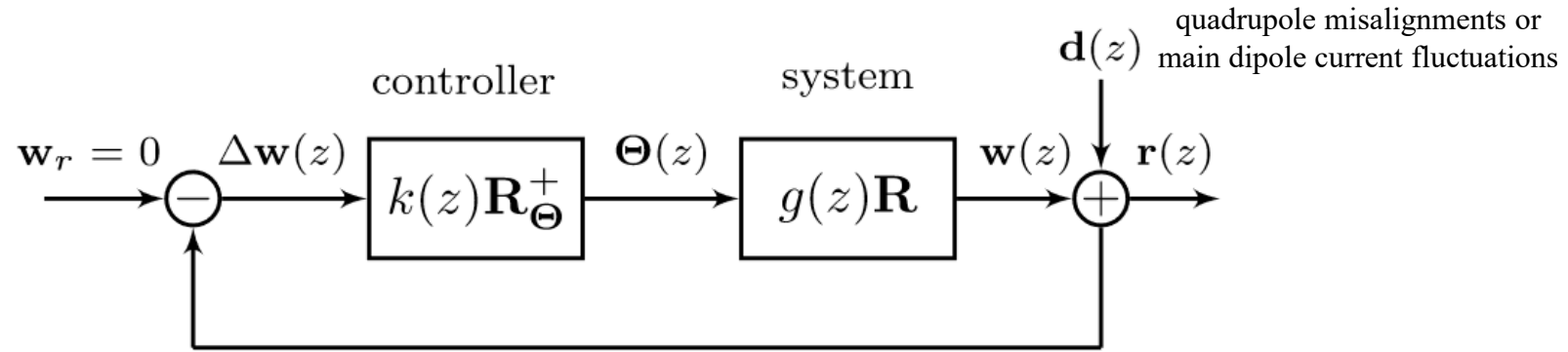

$$\text{system model } \mathbf{G}(z) = g(z) \mathbf{R}$$

We can separate the spatial and temporal parts of the system model

$$g(z) = g_l(z)_{\text{BPM}} \cdots g_m(z)_{\text{power supplies}} \cdot g_n(z)_{\text{correctors}}$$

$$\text{controller } \mathbf{K}(z) = k(z) \mathbf{R}^+$$

# A special feature of SIS18: optics variation over ramp

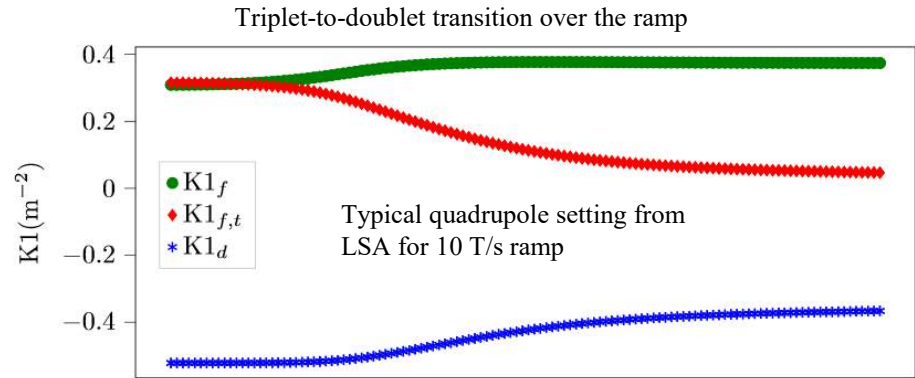

$$R_{mn} = \frac{\sqrt{\beta_m \beta_n}}{2 \sin(\pi Q_z)} \cos(|\mu_m - \mu_n| - \pi Q_z)$$

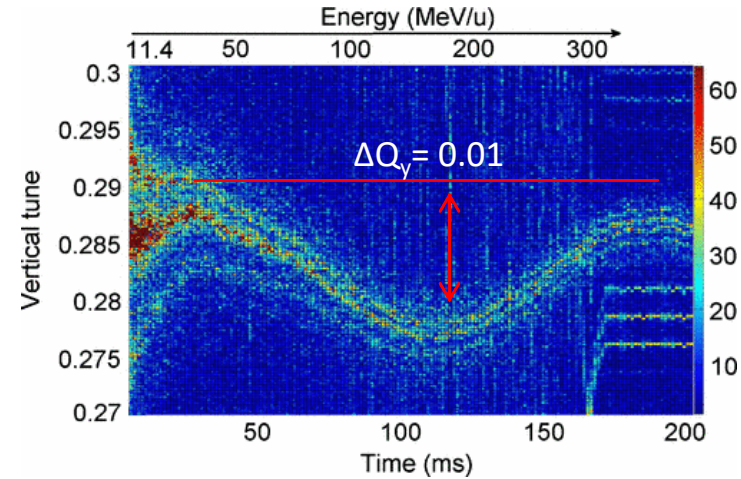

## Important questions before COFB commissioning

- ❖ How many ORMs need to be updated in the controller to avoid COFB instability?
- ❖ If ORM is fixed in controller, how controller parameters will scale with model mismatch?
- ❖ Variation of which parameters is crucial? tune (image charge induced tune shift) or beta function (beta beating)
- ❖ How much intensity dependent tune shifts can be tolerated by COFB system?

# Important investigations for design of SIS18 COFB

How many ORMs need to be updated in the controller to avoid COFB instability?

For slow regime: When the rate of orbit correction is too slow as compared to the dynamics of the system i.e. the system is in steady state before the application of next correction

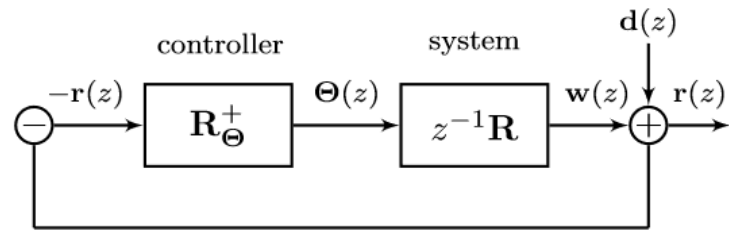

$\mathbf{R}$  is the system model

$\mathbf{R}_\theta^+$  is the controller model

first iteration residual (measureable)

$$\delta_1 = \frac{r_{1,RMS}}{w_{0,RMS}}$$

correction matrix(calculable)

$$\mathbf{M} = (\mathbf{I} - \mathbf{R}\mathbf{R}_\theta^+)$$

$$\rho(\mathbf{M}) = \max\{|\lambda_i|\}$$

$$\rho(\mathbf{M}) \geq \delta_1$$

The condition of COFB system stability is:

$$\delta_1 \leq 1$$

$$\rho(\mathbf{M}) \leq 1 \quad \text{The spectral radius condition of COFB stability}$$

simulations for SIS18

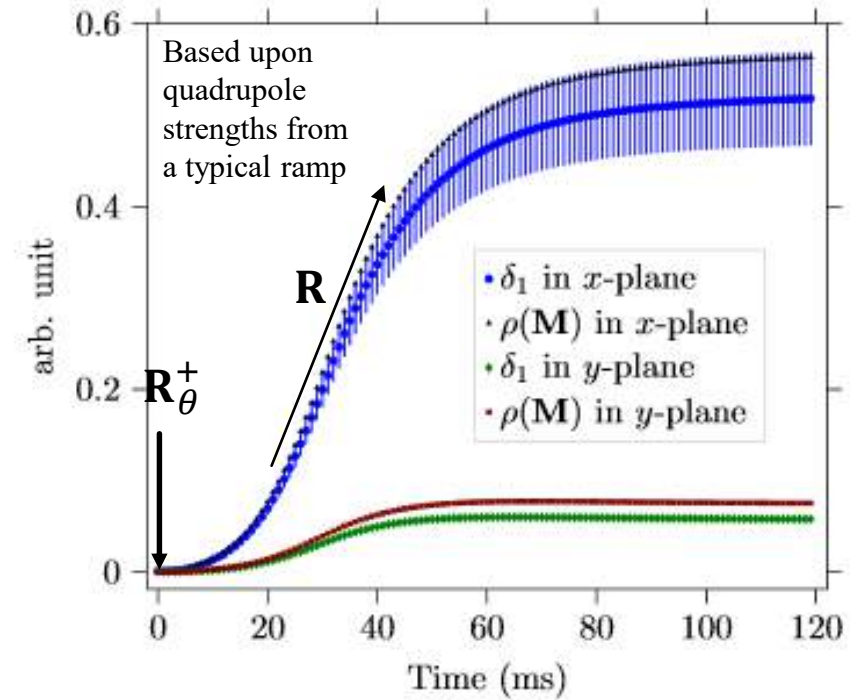



# Demonstration at COSY Jülich

The experimental demonstration of COFB instability due to spatial model mismatch was made at proton Cooler Synchrotron (COSY) of Jülich research center

The correction time for the COSY COFB system is  $T_s = 2s$  so it can be regarded as slow feedback system

- ❖ First, the machine settings were fixed corresponding to the vertical tune of 3.62 while the ORMs were updated in the COFB system for a range of tune values from 3.53 to 4.16.
- ❖ Secondly, the proton beam was accelerated from 45 MeV to 283 MeV and the orbit correction was performed at injection, mid-ramp (122 MeV) and extraction energies using only the ORM corresponding to extraction setting.

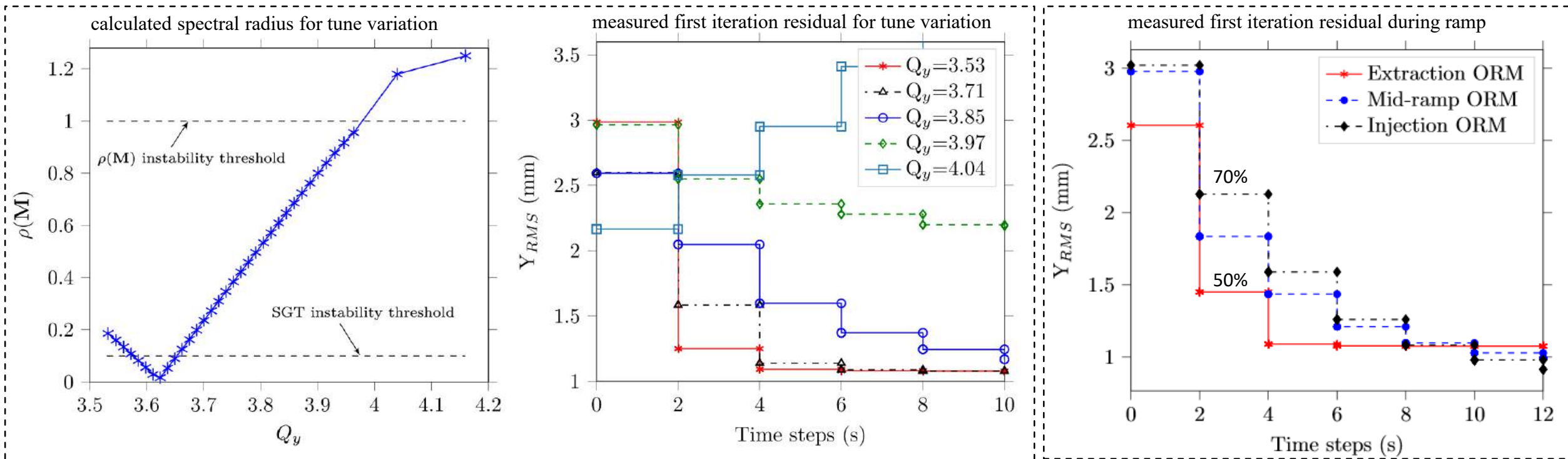

S. H. Mirza, R. Singh, P. Forck, B. Lorentz, Performance of the closed orbit feedback systems with spatial model mismatch, Physical Review Accelerators and beams (accepted for publication)

# Important investigations for design of SIS18 COFB

If controller ORM is fixed how should controller parameters vary with model mismatch to have persistent orbit correction and to avoid COFB instability?

For fast regime: When the rate of orbit correction is comparable to the dynamics of the system

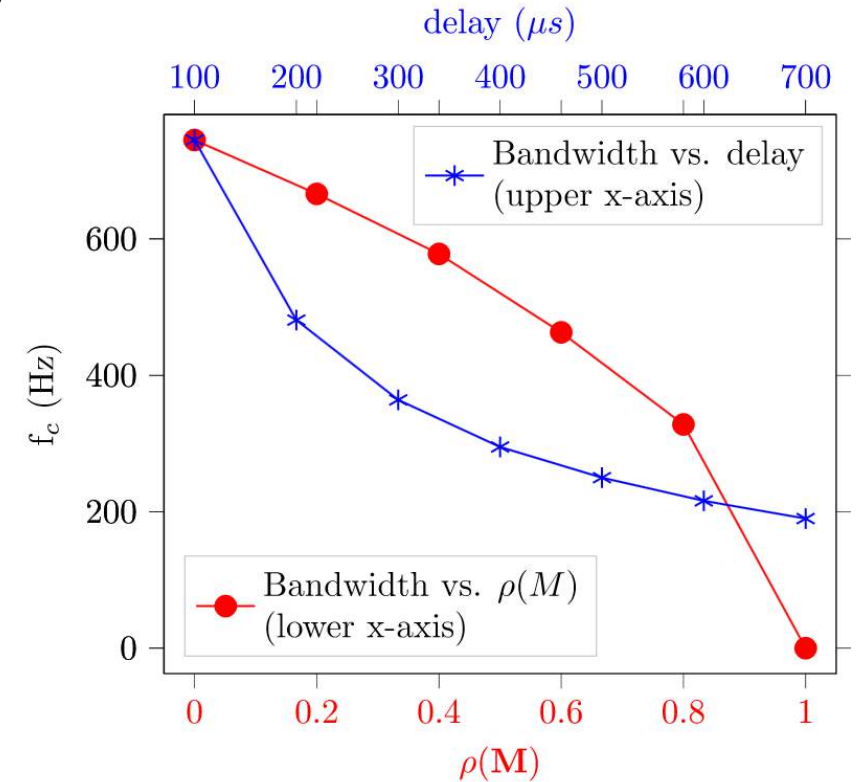
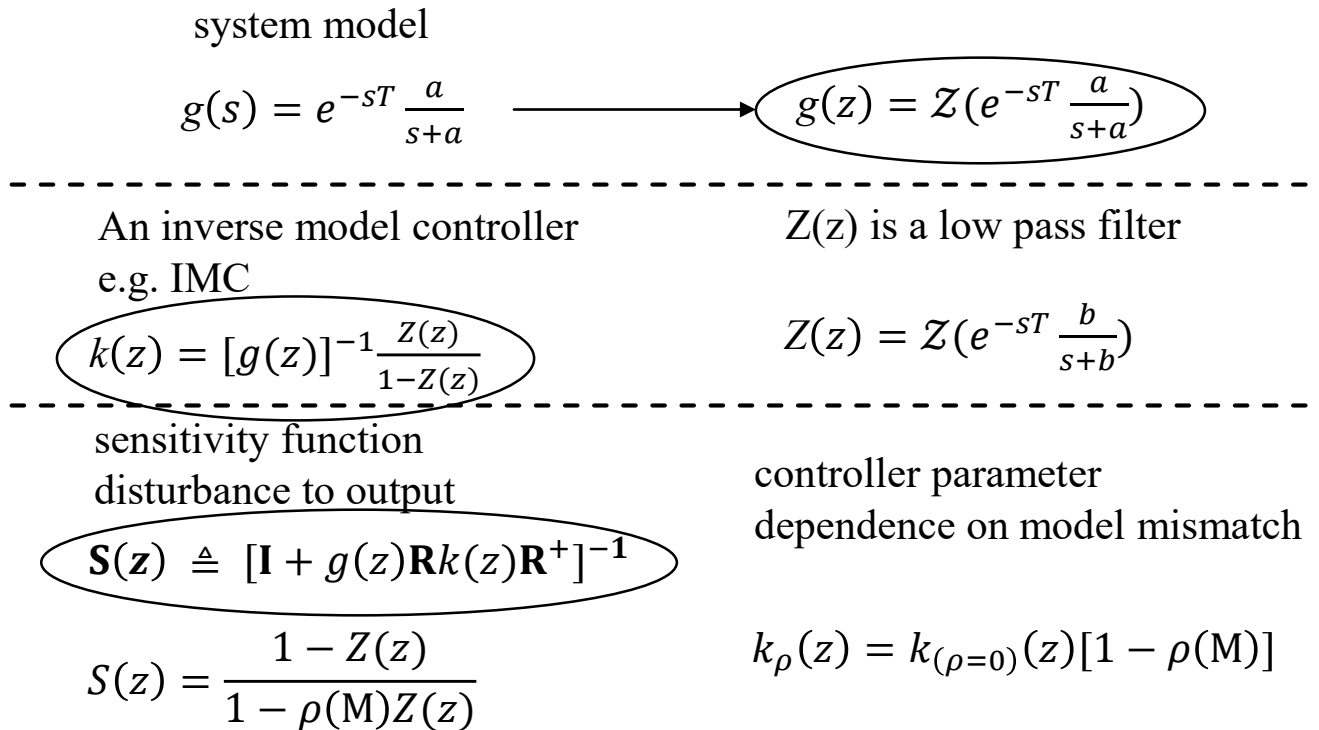

simulations for SIS18

M. Abbott, Using an Internal model controller for electron beam position fast feedback ,Diamond Light Source, internal document, (2007)

S. H. Mirza, R. Singh, P. Forck, B. Lorentz, Performance of the closed orbit feedback systems with spatial model mismatch, Physical Review Accelerators and beams (accepted for publication)

# SIS18 COFB hardware description

Libera Hadron PlatformB is used as for the processing of beam position data as well for the controller implementation

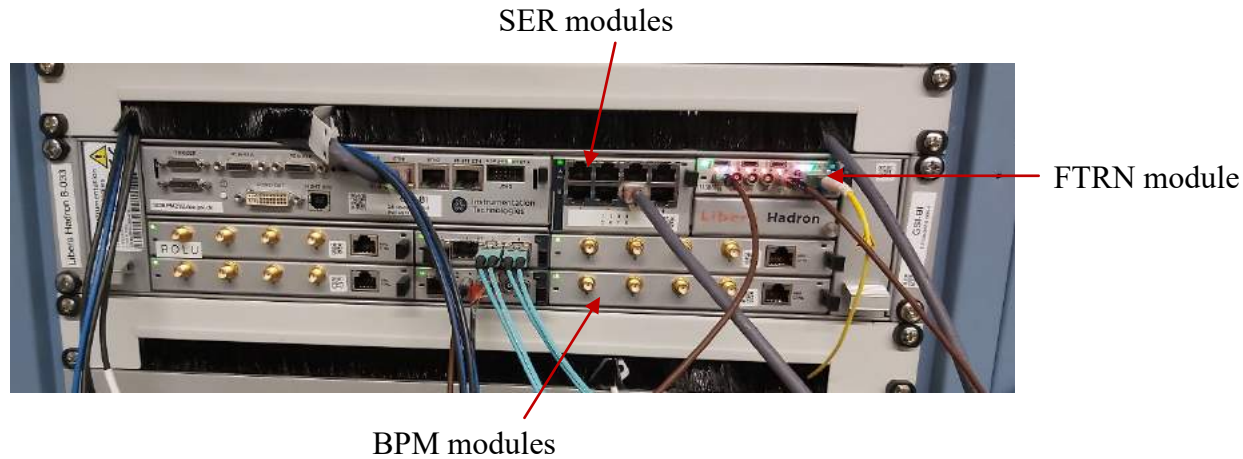

Hardware layout

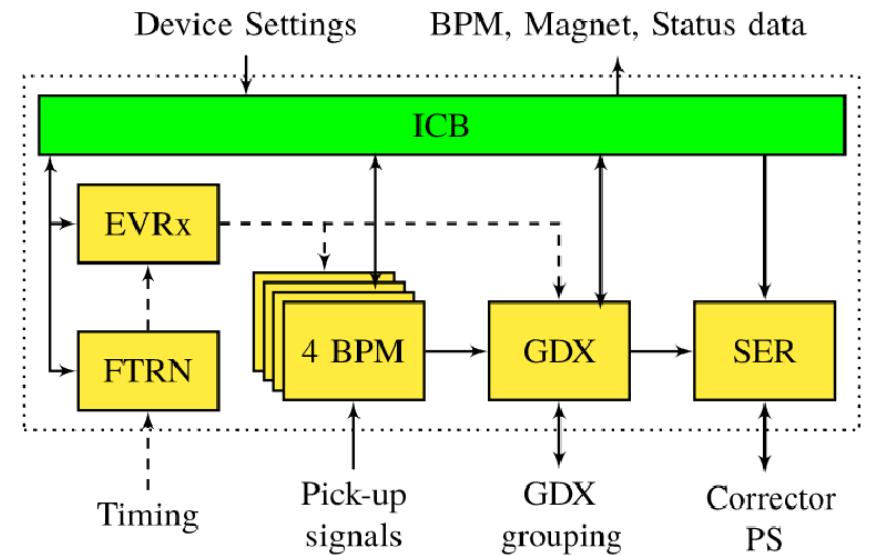

**BPM:** Beam position module

**EVRx:** Event Receiver module

**FRTR:** Fair Timing Receiver Node

**GDX:** Gigabit Date eXchange

**SER:** Serial communication module

# SIS18 COFB hardware description

SIS18 COFB design overview

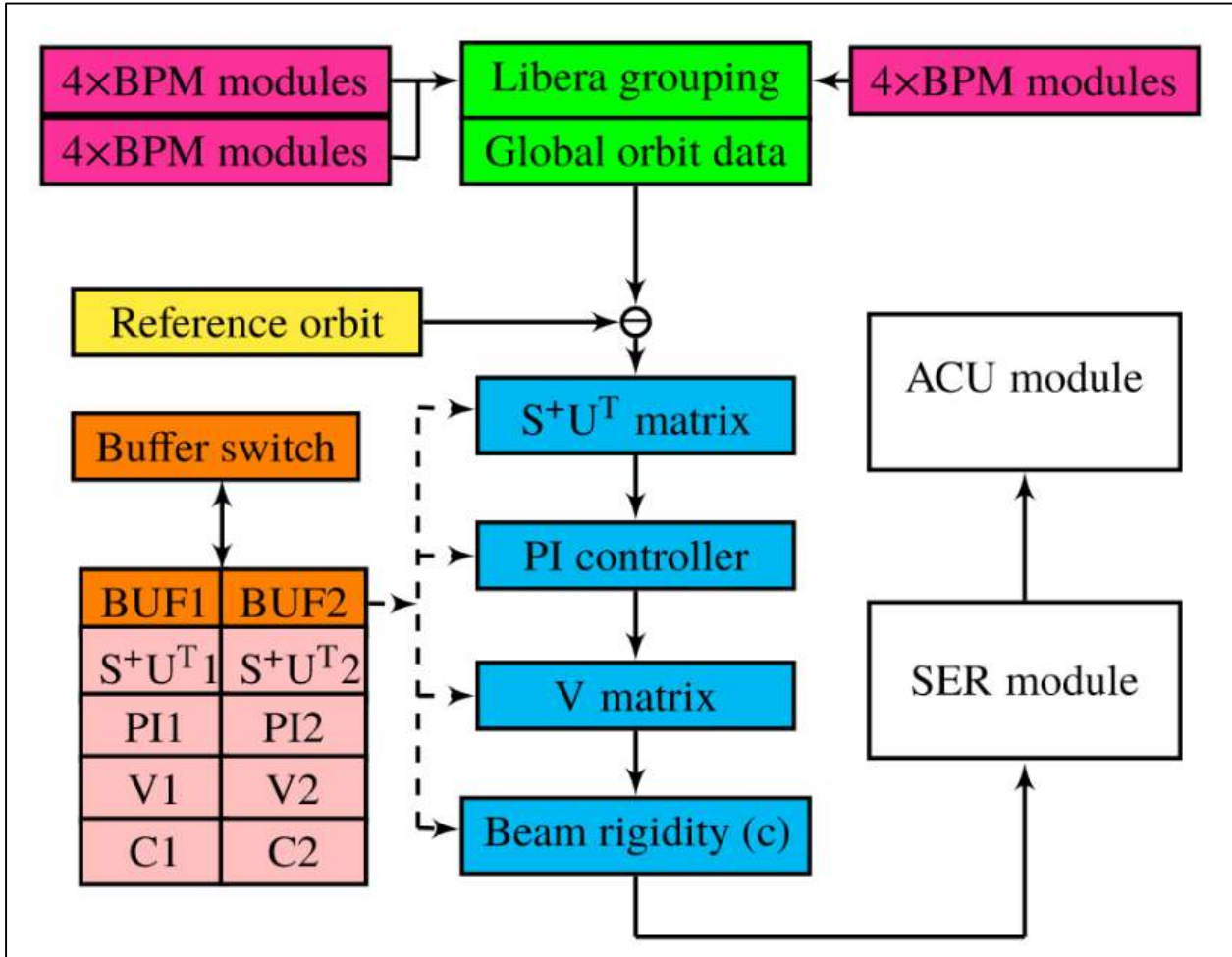

PI controller implementation

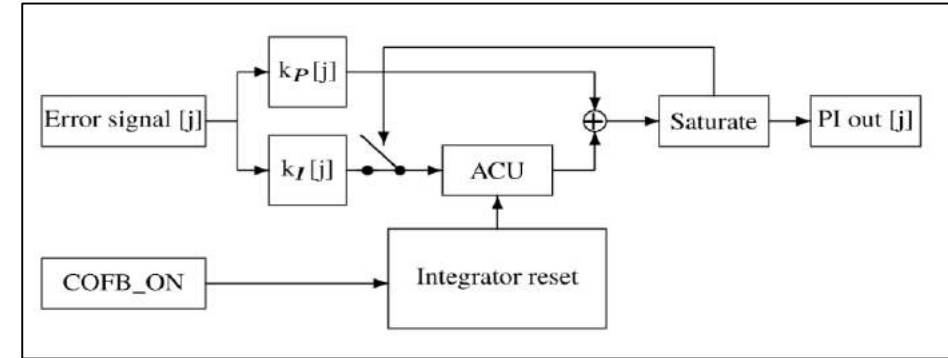

## Key features:

- ❖ Each Libera hadron can process data from 4 BPMs
- ❖ The BPM data is averaged over 100  $\mu$ s (called one FA cycle)
- ❖ Data shared between all Liberass and is grouped in GDX module to form closed orbit vector of size 12
- ❖ Controller is implemented in GDX module
- ❖ Each Libera has 8 outputs of steerer strengths
- ❖ Two buffers are implemented for the online parameter update
- ❖ The steerer strengths are sent to the adaptive control units via Ethernet cables which then governs the steerer currents.
- ❖ A synthetic generator is also implemented in SER module

# Measurement of model mismatch over ramp for SIS18

**Beam:**  $^{40}\text{Ar}^{+18}$  **Number of particles:** 1.0E8 **Injection Energy:** 11 MeV/u **Extraction energy:** 300 MeV/u

The synthetic signal generator implemented in SER module of Libera hardware was used for the excitation of the beam through all steerers one by one.

Excitation of 70 Hz and amplitude corresponding to 1 mrad was applied and the resultant response was normalized with the beam rigidity (left figure)

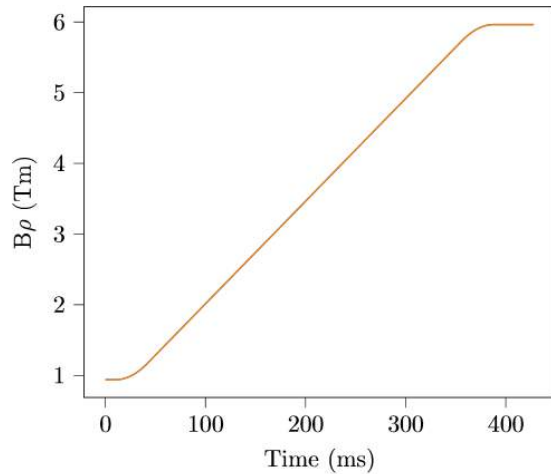

A clear change in the response of the closed orbit over the ramp can be seen.

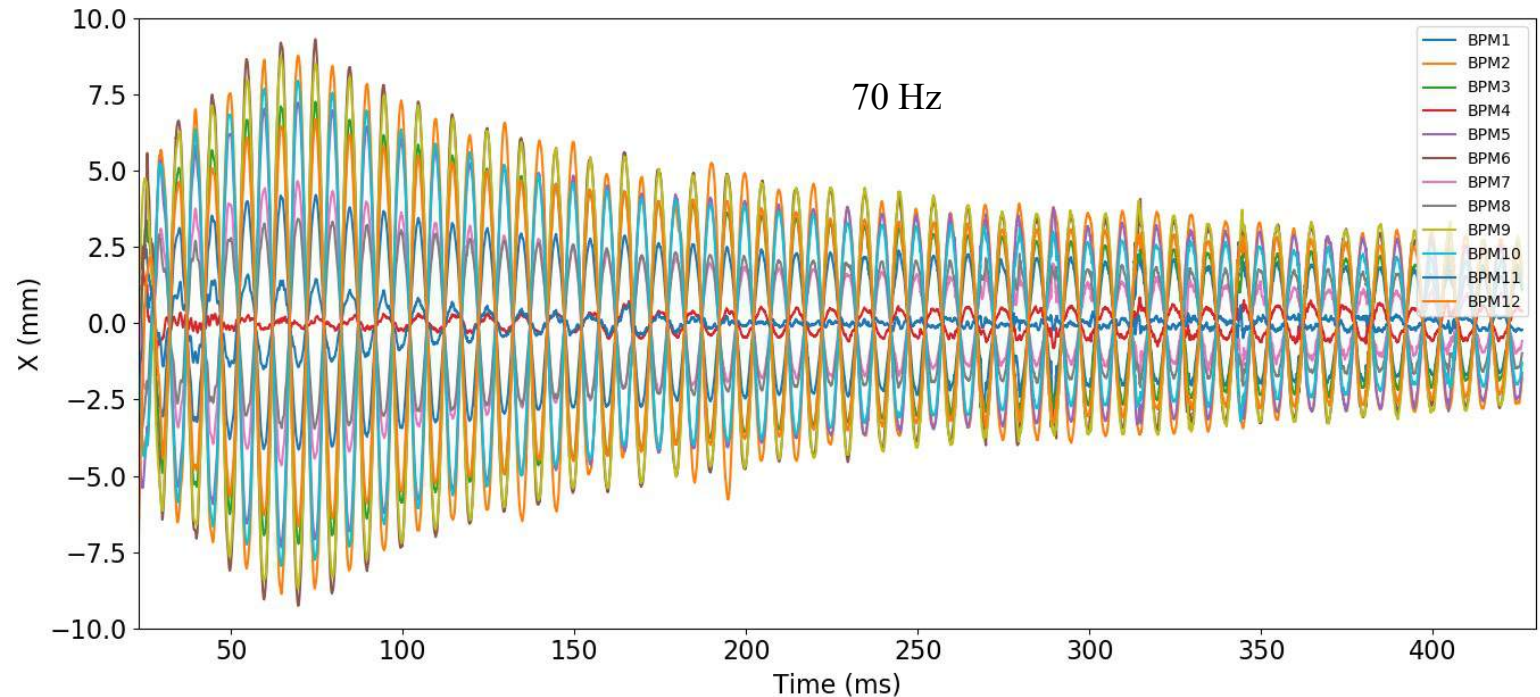

This method of ORM measurement is robust to any BPM offsets as well as provides the ORM change during the ramp

# Measurement of model mismatch over ramp for SIS18

**Beam:**  $^{40}\text{Ar}^{+18}$  **Number of particles:** 1.0E8 **Injection Energy:** 11 MeV/u **Extraction energy:** 300 MeV/u

The left figure shows the variation of the highest singular value of the measured ORM over the ramp

The right figure shows the spectral radius of the correction matrix i.e.  $\rho(\mathbf{M}) = \rho(\mathbf{I} - \mathbf{R}(\mathbf{t})\mathbf{R}_{\theta, \text{injection}}^+)$  with respect to injection ORM for both measured and madx model ORMs

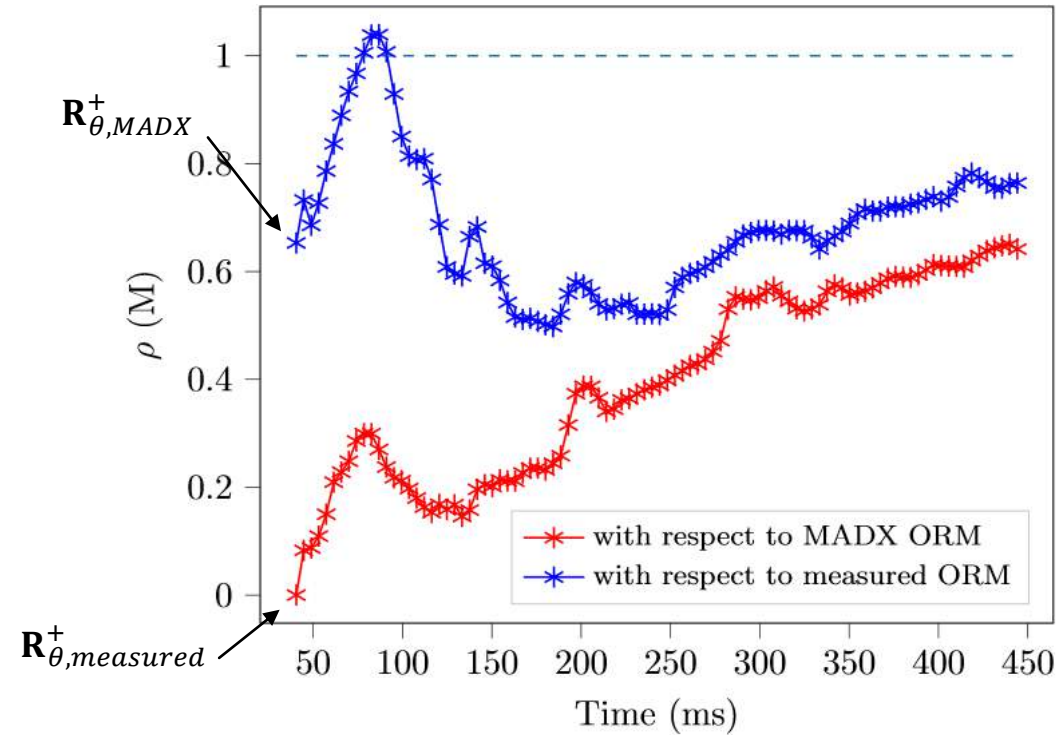
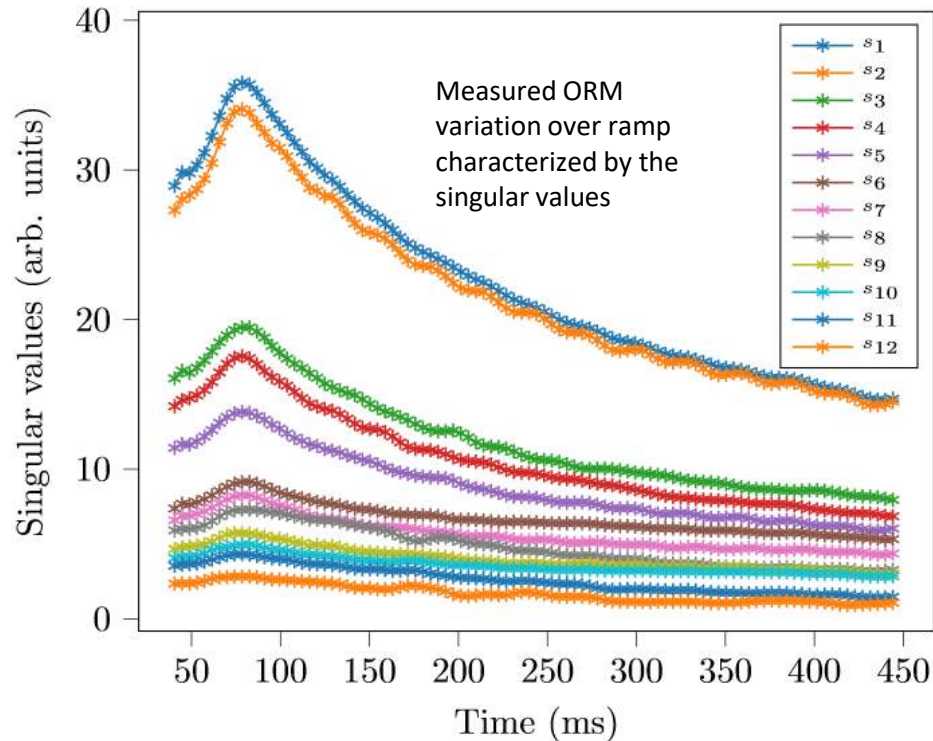

# Temporal system identification: transfer function measurement

The open-loop frequency response was also measured using the synthetic generator implemented in the SER module. The schematic of the setup is shown below (left).

Beam\_ON event was used as an external trigger to Oscilloscope for the delay measurement.

The components included in the loop are steerer power supply, magnet, vacuum chamber, BPMs and Libera hardware

The measurement was made in the same “correction space”

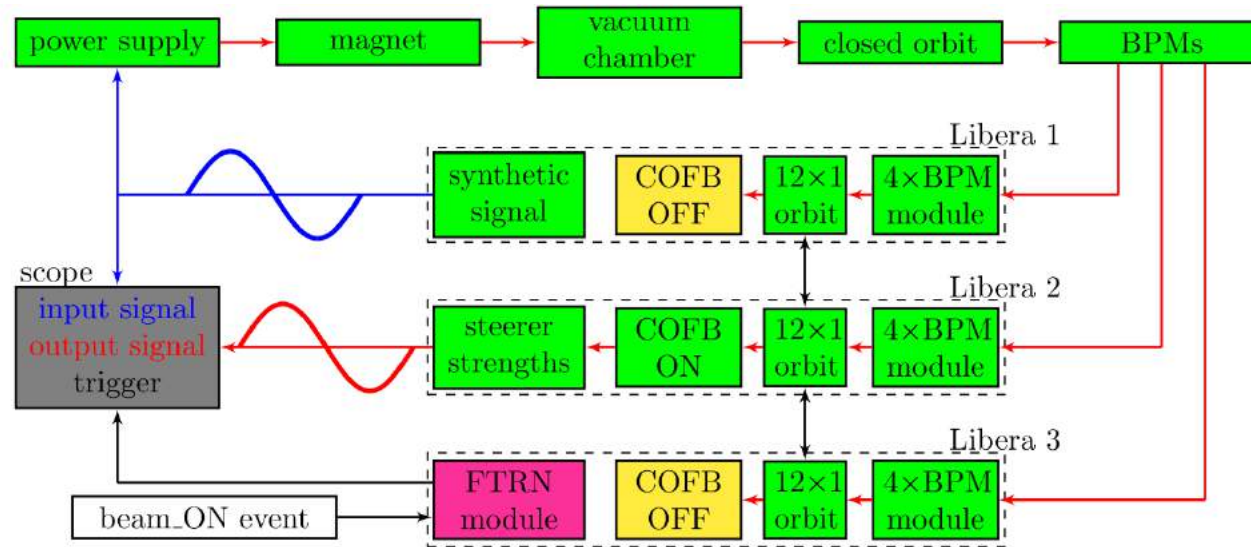

Steerers were found to have different dynamics which pose extra complexity for the COFB system and achievable bandwidth.

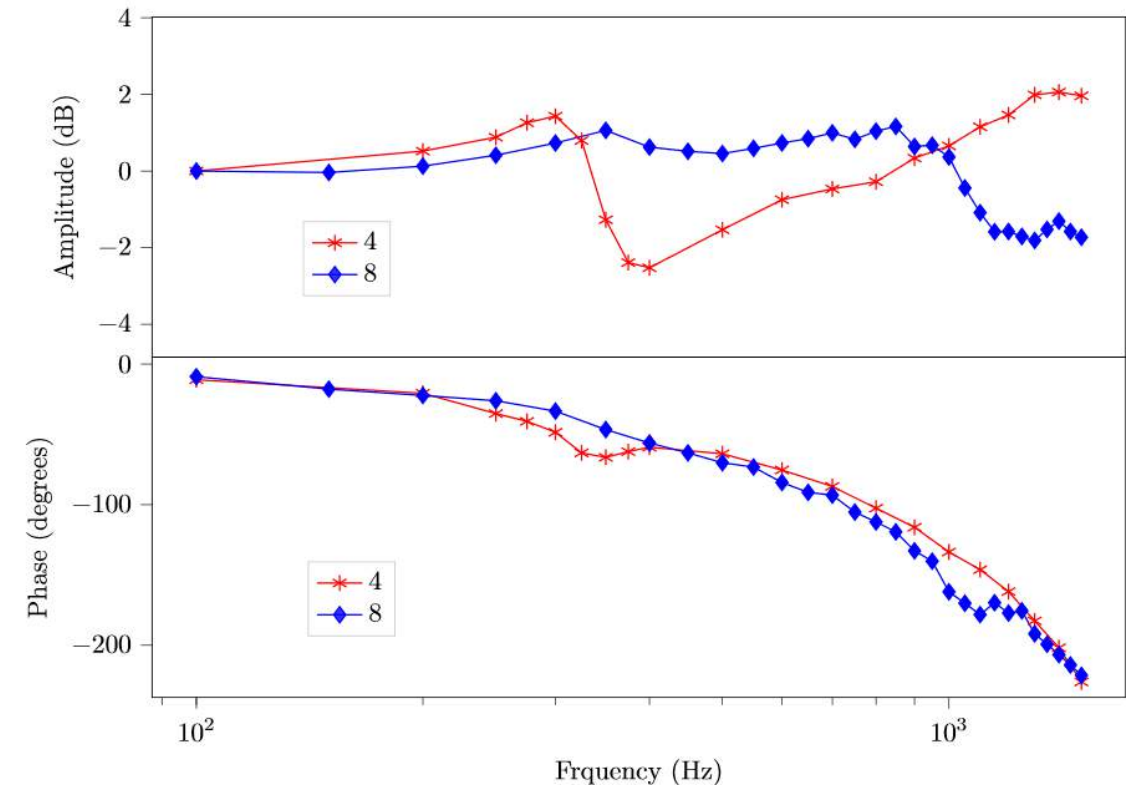

# Final demonstration: on-ramp orbit correction in SIS18

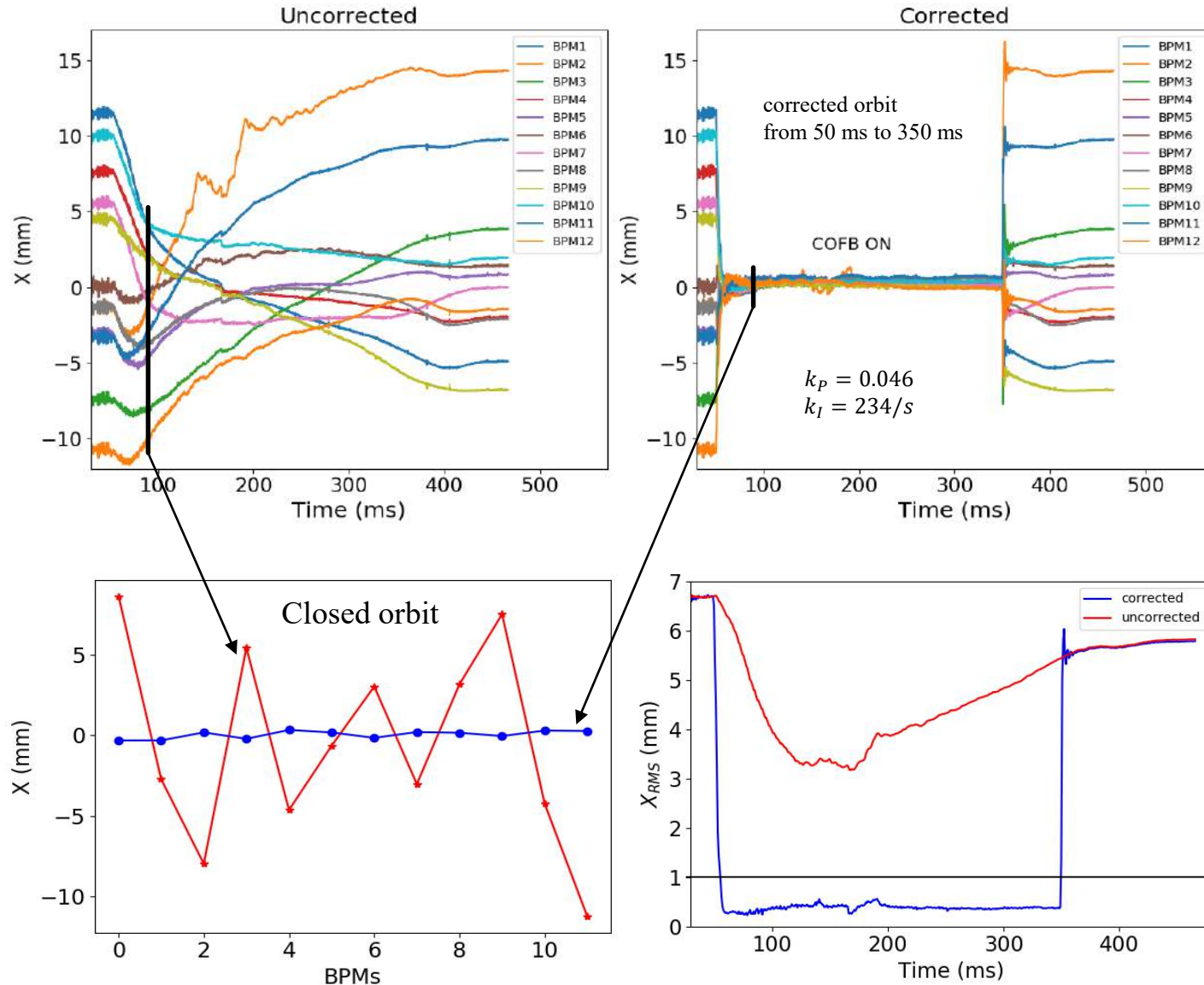

- ❖ Fast and robust SIS18 closed orbit feedback system is an implementation first of its kind for the on-ramp orbit correction.
- ❖ The closed orbit RMS in horizontal plane was reduced to below 1 mm. The RMS should be less than 10% of the beam size. Correction up to 300 Hz was achieved (not shown here).



# Final demonstration: on-ramp orbit correction in SIS18

A new feature of piecewise variation of Golden orbit over the ramp is implemented in COFB algorithm as per user's demand. A maximum of 64 different Golden orbits can be adjusted for one ramp.

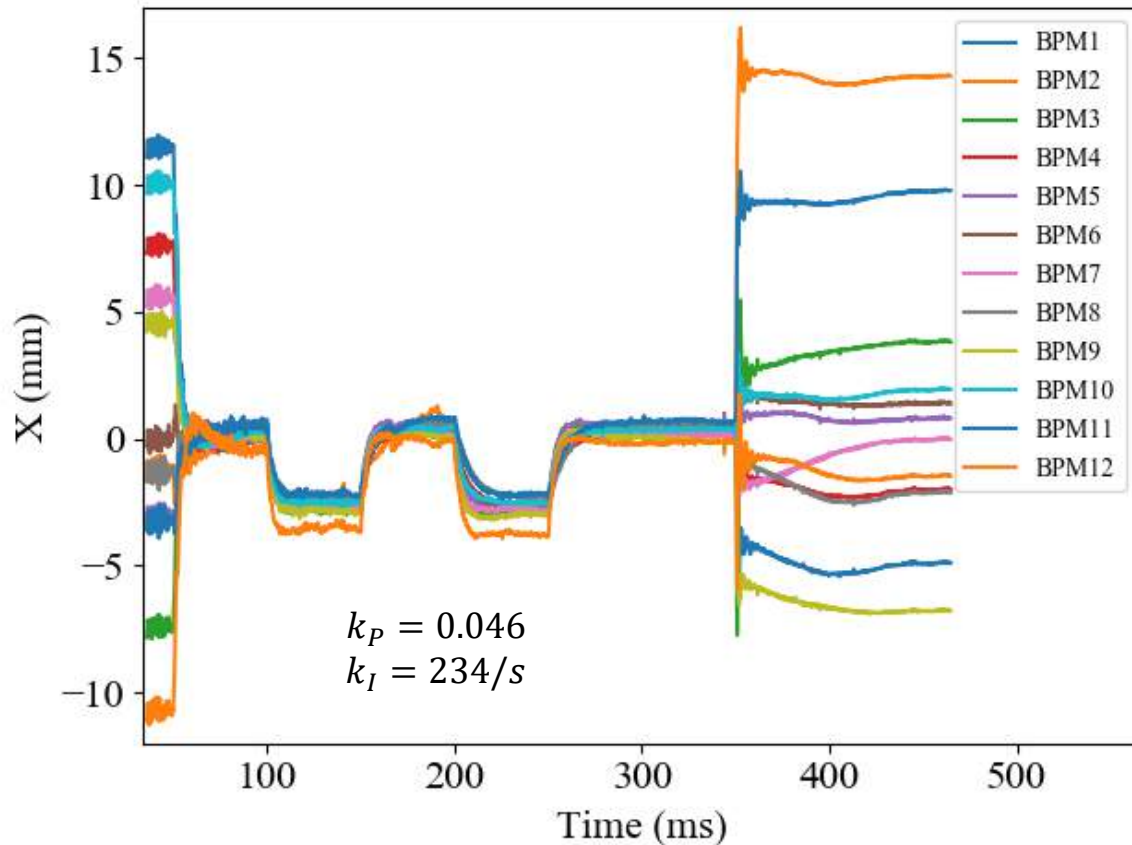

Model mismatch puts an upper limit on the controller parameters as  $k_p(z) = k_{(\rho=0)}(z)[1 - \rho(M)]$  in order to avoid COFB instability. The model mismatch-induced oscillations are shown below when the controller parameters are not optimized with model mismatch

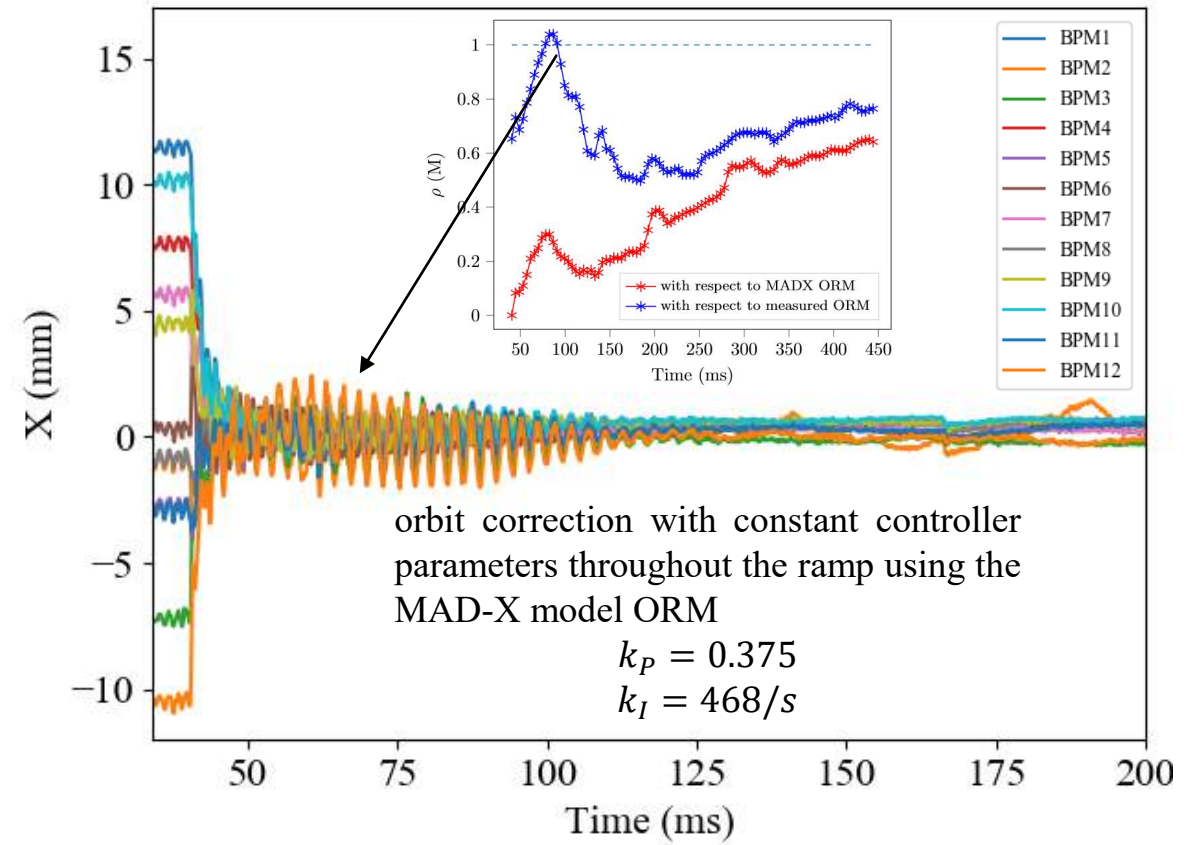

# Summary

- ❖ A fast and robust closed orbit feedback system has been commissioned for SIS18. The Libera Hadron PlatformB is used for the controller implementation as well beam position data processing.
- ❖ Theoretical investigations were performed beforehand in order to understand:
  - the possibility of closed orbit correction during the ramp. The condition of COFB instability was established.
  - the effect of model mismatch on the achievable bandwidth of the COFB. The bandwidth decreases with model mismatch.
  - the dependence of the controller parameters on the magnitude of the model mismatch.
- ❖ The theoretical conclusions are verified experimentally at COSY synchrotron Jülich.
- ❖ The ORM over the ramp was measured using the synthetic generator of the Libera Hadron and the model mismatch was measured with respect to the injection ORM.
- ❖ The open loop system identification was also performed using the synthetic generator of the Libera Hadron. Steerers are found to have different transfer functions.
- ❖ The orbit correction is performed over the ramp and the closed orbit RMS below 1 mm is achieved.
- ❖ The effect of model mismatch on the closed orbit stability is also demonstrated experimentally in SIS18.

## Acknowledgement

**GSI Beam Instrumentation:**  
P. Forck, K. Lang, M. Schwickert  
**GSI System design:**  
D. Ondreka

**GSI Power supply :**  
A. Doering, W. Orlov, D. Rodomonti, D. Schupp, H. Welker  
**I-Tech:**  
M. Bajic, A. Bardorfer, D. Tinta