

# BPM SYSTEM AND FAST ORBIT FEEDBACK UPGRADE FOR THE TAIWAN LIGHT SOURCE

C.H. Kuo, P.C. Chiu, K. H. Hu, Jenny Chen, C.Y. Wu, Demi Lee, K.T. Hsu  
NSRRC, Hsinchu 30076, Taiwan

## Abstract

The BPM electronics of the Taiwan Light Source (TLS) have been upgraded to the Libera Brilliance in August 2008 to improve performance and functionality. Orbit feedback system is also migrated into fast orbit feedback system to enhance orbit stability. Infrastructure of the orbit acquisition system and orbit feedback system has been reconstructed to accommodate the new BPM electronics and to satisfy requirements of fast orbit feedback loops. Gigabit Ethernet grouping was adopted for the data transfer of 10 KHz rate orbit data to the orbit feedback system. The efforts and performance of this upgrade will be summarized in this report.

## INTRODUCTION

Orbit stability is an extremely important for a modern synchrotron light source. Generally, beam motion should be less than 10 % of its beamsize or even smaller. There are many efforts make to improve orbit stability of Taiwan Light Source (TLS) such as control of the ambient environment, removing various mechanical vibration passively, feed-forward compensation of insertion devices, locating faulty power supply and etc. Nevertheless, the limited loop bandwidth led incapability to suppress fast orbit excursion above 6 Hz. The fast orbit feedback system was thus proposed. The commissioning of the new fast orbit feedback system will come to an end soon. In the report, the upgrade progress and performance of the BPM system will be presented. Measurement of the system response and latency are discussed next. Finally, the infrastructure and performance of fast orbit feedback are summarized.

## BPM SYSTEM UPGRADE AND ACQUIRED DATA MEASUREMENT

The Libera Brilliance [1] is employed to replace the existed BPM electronics for the TLS. Its integration started from 2007 until finish in August 2008. It was gradually deployed and performed without interfere routine operation. There are 59 Libera Brilliances online operation for more than 8 months. The adequate long-term reliability has been achieved. The typical Libera acquired slow and fast data which are extreme critical for FOFB performance will be shown in the latter.

### Libera Grouping

The Libera provided a Gigabit Ethernet interface to transfer data with 10KHz update rate. The data sending in

the same time, there is network packet collision and interrupt queue over buffer problem in the receiving node. That will take fatal jitter effect and data lost. To eliminate this phenomenon, Libera Brilliance units are grouped together by a redundant multi-gigabit links via the LC optical links and copper “Molex” cables. This link can exchange the data among all Libera Brilliance units to be a single and large packet size by FPGA and send the gathered data via Gigabit Ethernet. It is effective to reduce the packet numbers in network, banish jitter and data lost in the communication with processor [3,4].

### Fast Data

Resolution is an important issue for fast orbit feedback system. The resolution of the Liberas FA data at 10 kHz is around 0.2~0.3  $\mu\text{m}$  when the simulated beam current intensity is operated at 300 mA. Each unit slightly differs while the whole of 59 Liberas should be within 0.35 $\mu\text{m}$ .

### Slow Data

Vertical orbit data is shown as Fig. 1. The standard deviation is around 0.1~0.8 with real beam corresponding to respective location.

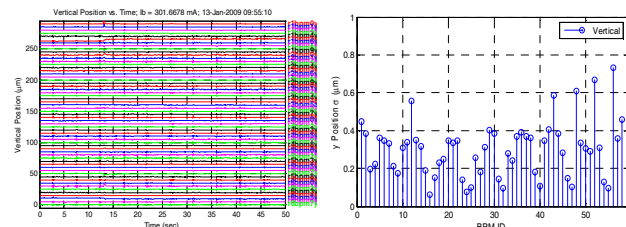

Figure 1: Slow data of vertical position and its RMS value.

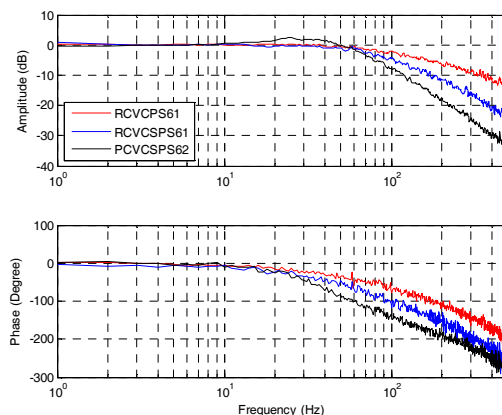

Figure 2: Three vertical correctors' (RCVCPS61, RCVCS61, RCVCS62) response functions.

## VARIOUS SYSTEM MEASUREMENT SUMMARY

There are several kinds of corrector magnets installed in the TLS due to historical reasons. They have different response. To understand the compound response of the power supplies, correctors, vacuum chamber and the stored beam, pseudo-random binary sequence (PRBS) excitation is employed to measure system response and latency.

### Open Loop System Response

The various correctors are installed in the storage ring of the TLS at different period section; Fig. 2 shows the overall PRBS response of the three vertical correctors in section R6. It includes power supply, corrector, vacuum chamber, correctors to BPM readings. The dynamics of these three correctors differ from each other. There are some vertical correctors' bandwidth that can achieve to 80 Hz, but others may be below 30 Hz, through measurements around the whole storage ring. Choosing the proper correctors for FOFB is thus necessary.

### Latency Time Evaluation

The estimated I/O latency time is around 500  $\mu\text{sec}$  of which is at the peak location of the cross-correlation function between the corrector action and BPM response, as shown in Fig. 3.

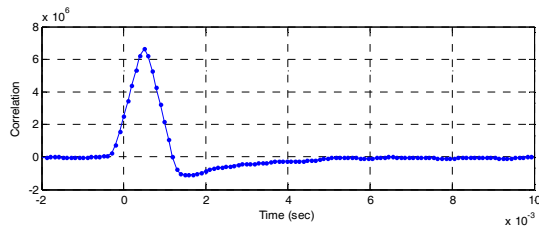

Figure 3: Cross-correlation function of PRBS sequence and BPM reading, the peak location corresponding to the overall latency from the DAC output the BPM reading.

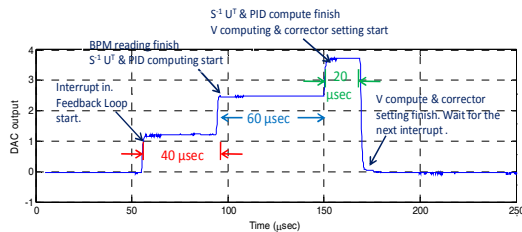

Figure 4: DAC output level is changed when each computing step is finished. The interval between two adjacent difference levels represents the respective latency for each computation.

Processing latency of the data acquisition and computation are also detailed evaluated as Fig. 4. Transfer BPM data, rearrangement and scaling takes around 40  $\mu\text{sec}$ ;  $S^{-1}U^T$  matrix (response matrix  $R=USV^T$ )

and PID computation around 60  $\mu\text{sec}$ ; V matrix computation and DAC settings 20  $\mu\text{sec}$ . The time for whole feedback loop takes about 120  $\mu\text{sec}$ . It infers that we can push feedback sampling frequency from the current 1.25 kHz to higher frequency under constrains of the current orbit feedback infrastructure which is implemented in economic way. The overall latency time is about 620  $\mu\text{s}$  that includes of calculation, chamber eddy current effect, bpm reading and corrector setting delay,... etc.

## FOFB INFRASTRUCTURE AND ALGORITHM

The infrastructure of the new orbit feedback system is shown in Fig. 5. The orbit controls for the horizontal and vertical plane are separated from the old version to increase available computation power. The reflective memory is employed to shares fast orbit data without consuming extra CPU resource and support data acquisition for other subsystems.

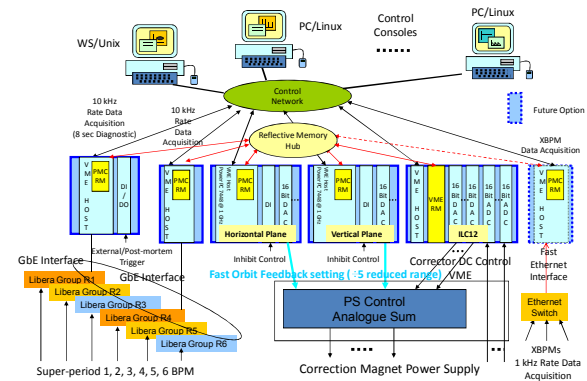

Figure 5: Infrastructure of the new FOFB and the related subsystems

### Tikhonov Regularization

Orbit response matrix R is a linear mapping, between the orbit and the steering magnet relation. Singular value decomposition, as a most commonly is used to invert this mapping in the feedback correction algorithm [5,6]. Furthermore, to obtain a stable solution, Tikhonov regularization is also adopted [3,6].

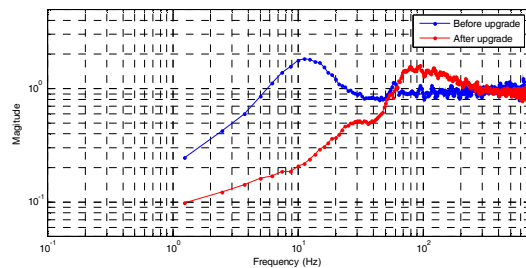

Figure 6: Noise sensitivity function comparison before and after FOFB upgrade.

## PRELIMINARY PERFORMANCE TEST

### Noise Sensitivity Function Measurement

The bandwidth and performance of FOFB are measured and estimated by PRBS. Fig. 6 shows that the new FOFB is promoted to suppress noise of bandwidth to around 60Hz from old 6Hz system after all components are upgraded. The new BPM performance in wideband is better than before. As a result, vertical orbit stability can be reasonably expected down to submicron from DC to 60Hz.

### Orbit Stability for User Operation

The feedback system can improve beam stability as shown in Fig. 7 and Fig. 8. The standard deviation of all BPM reading can be reduced to 0.2  $\mu\text{m}$  from 0.8  $\mu\text{m}$  between feedback on and off in the normal user mode for vertical plane. Both of horizontal and vertical orbit displacement can be less than one micron in SA readings.

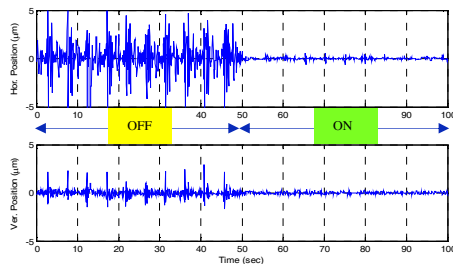

Figure 7: R6BPM7 SA data for FOFB ON/OFF.

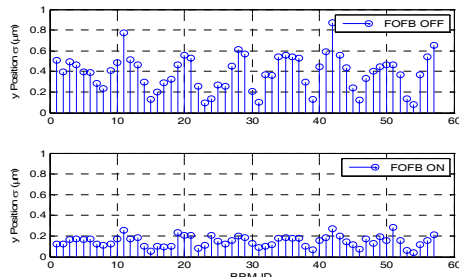

Figure 8: The standard deviation of vertical orbit displacement between FOFB on/off.

Figure 9 shows the R6BPM7 FA data spectrum comparison when FOFB on and off. The orbit stability can be suppressed to one micron at this location with higher  $\beta$  function therefore the overall RMS orbit stability should be submicron from DC to 50 Hz.

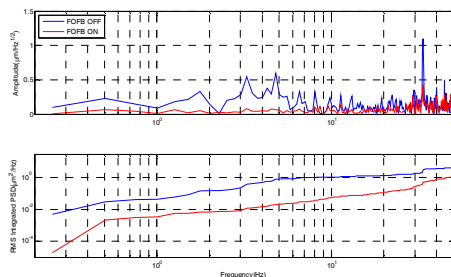
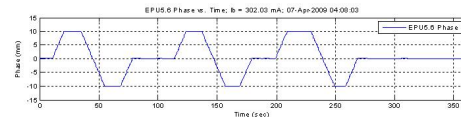

Figure 9: The spectrum and integrated PSD of R6BPM7 for FOFB on/off.

### Effects of FOFB for Insertion Device Operation

Fast operations of gap and phase of the insertion devices are highly desirable. However, the old orbit feedback loop cannot effectively suppress the orbit excursion when insertion devices gap or phase motion is fast than the limited component and bandwidth. The wider bandwidth of the new orbit feedback loop can promote the motion speed. Fig. 10(a) shows the 1 mm/sec phase move of the EPU5.6. The orbit displacement is shown in Fig. 10(b). It is clearly observed that the feedback loop can eliminate the orbit excursion.



(a) History of the EPU5.6 phase motion at speed of 1 mm/sec.

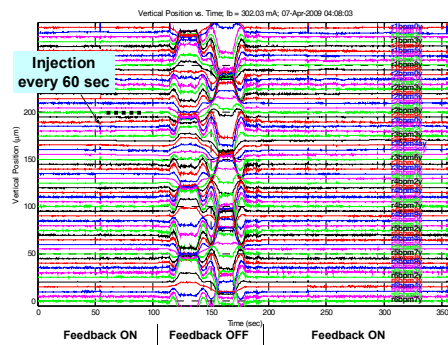

(b) Beam position reading of all BPMs

Figure 10: Effect of the new FOFB to suppress orbit excursion of 1 mm/sec phase change of EPU5.6.

## SUMMARY

Infrastructure of the FOFB for TLS has been revisited. Commissioning of the FOFB system is on going. Various R&D including modelling, measurement, control rules, and etc. are in proceed. Preliminary results and many exercises confirmed that the FOFB system effectively improve orbit stability.

## REFERENCES

- [1] I-Tech website: <http://www.i-tech.si>.
- [2] C. H. Kuo, et al., "Fast Orbit Feedback System Upgrade with New Digital BPM and Power Supply in the TLS", DIPAC'07
- [3] C. H. Kuo, et al., "Fast Orbit Feedback System Commissioning of the TLS", PAC'09
- [4] A. Bardorfer, et al., "LIBERA GROUPING: Reducing the Data Encapsulation Overhead", Proceedings of the EPAC08, TUPC003
- [5] A. Terebilo, et al. "Fast Global Orbit Feedback System in Spear3", EPAC06.
- [6] J. Rowland, et al. "Status of The Diamond Fast Orbit Feedback system", ICALEPCS07.