

**Libera**  
**LLRF**

# Digital RF Stabilization System

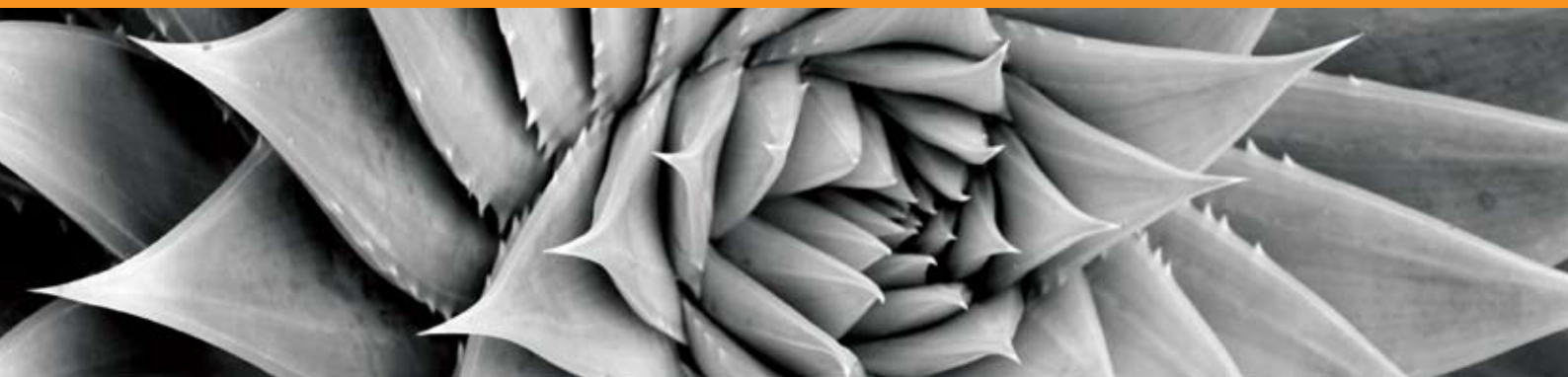

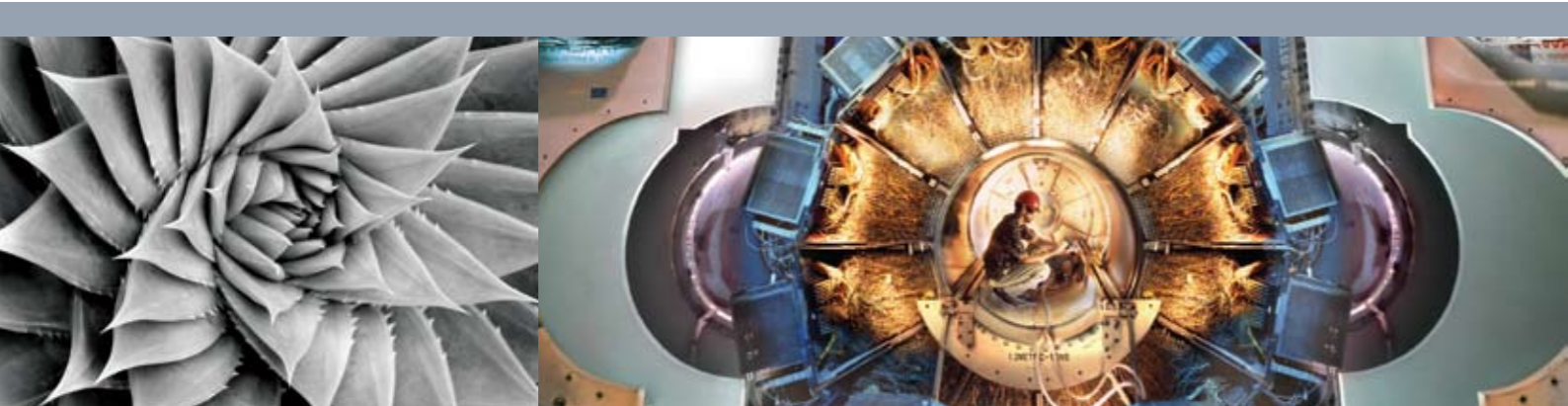

## Many instruments. Many people. Working together.

Stability means knowing your machine has innovative solutions. For users, stability means a machine achieving its full potential, enabling them to do more science. For us, stability means synchronized, connected, dynamic state-of-the-art instrumentation, working together as one system.

Because we know that the machine is more than just the sum of its parts.

*Libera LLRF stabilizes the accelerator's RF field by applying real-time digital feedback and feed-forward.*



## Benefits

### All-in-one

The all-in-one unit replaces a field of different instruments and crates:

- built-in RF system diagnostics: automatic phase and gain correction, cavity field control loop stability analysis, cavity decay analysis monitoring
- cavity tuning included
- cavity field stabilization: jitter cancellation, vector sum alignment, calibration system, computation of the cavity field vector sum, cavity field control by means of a programmable PI controller, feed-forward system
- built-in interlock system
- self calibration
- chassis health monitoring
- built-in local oscillator generation

### Customizable

- SW configurable controller: easy upgradeable firmware
- using the Libera LLRF field programmable gate array (FPGA) pre-build blocks that interfaces with the hardware, it is possible to customize the product to your specific needs
- FPGA development kit available
- customizable RF input frequency up to 12 GHz
- up to 32 cavity signals per station
- FPGA facilitates fast signal processing and logic interfacing
- easy maintenance through modularity

### Ready to integrate in the control system

- network-attached device
- the Libera LLRF high-level software library measurement and control interface (MCI) separates control-system specific knowledge from low level details and logic related to a Libera processor

### Suitable for the latest generation light sources and hadron accelerators

- phase and amplitude stability meets 4th generation light sources' requirements
- compatible with normal-conducting and super-conducting RF systems
- supports pulsed and continuous wave operation modes
- low latency

## Role in the Accelerator

Libera LLRF is an industrial digital RF stabilization system. The system can be used to control normal and superconducting accelerating structures. Both pulsed and CW operation modes are supported. The high-performance field stabilization meets the 4th generation light sources' requirements.

The Libera LLRF system is a programmable network-attached device. The user can connect different RF inputs to the unit: cavity probes and directional coupler signals, and therefore easily configure the software to perform different LLRF functions such as cavity field stabilization, cavity and waveguide tuning, and RF system diagnostics.

## How Does It Work?

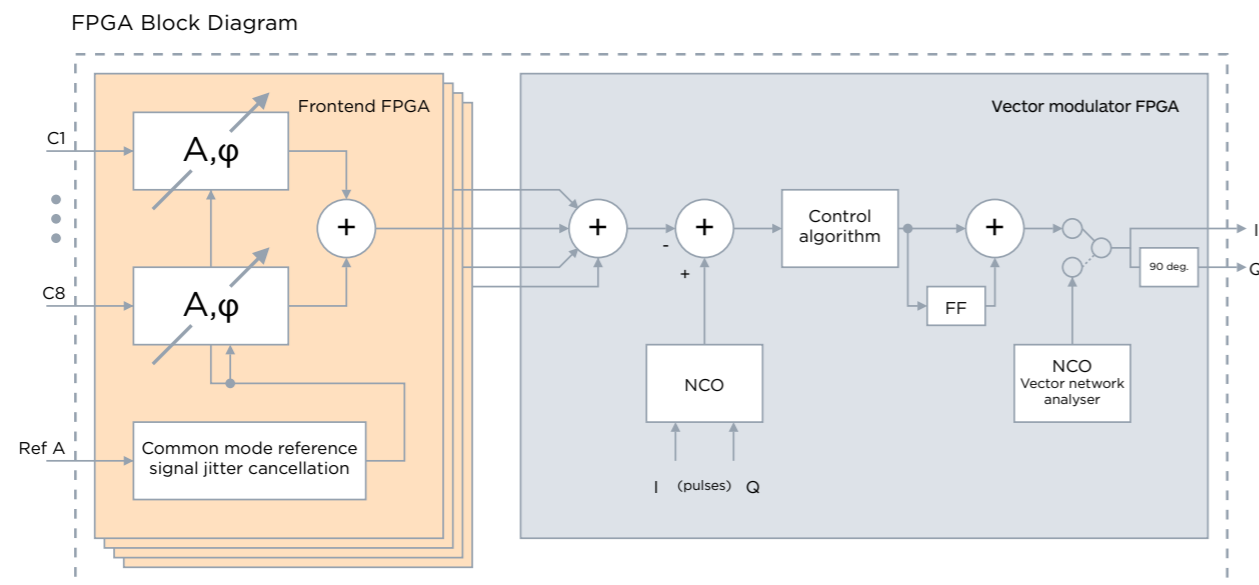

The Libera LLRF system can process up to 38 RF input signals per unit. Probe, forward and reflected signals are connected to the RF inputs of one or more Libera LLRF units. Each unit can populate up to 4 front-end modules. The front-end modules are equipped with temperature stabilization and drift compensation systems. Each RF front-end module converts 9 RF input signals to an IF frequency. The converted signals

are then sampled by the 16-bit ADCs. The sampled IF signals are subsequently processed in real time in a powerful Virtex 5 FPGA. The partial vector sum is transferred to the vector modulator module by means of a low-latency link. In the vector modulator module, another Virtex 5 FPGA implements the LLRF control algorithm, and an RF output drive signal is generated and applied to the transmitter.

The Libera LLRF high-level application software performs RF system response characterization and therefore uses the results for automatic loop stability optimization. The system can also be used to provide optimal RF system frequency tuning and optimal RF distribution system tuning by means of the implementation of slower tuning loops. During operation, the system provides diagnostics information to the user and triggers the interlock if a failure is detected.

## Parameters

Parameter	Value
Number of input channels	36 (9 per module)
ADC resolution	16 bits
Max. ADC sampling clock frequency	130 MHz
Memory size per module	up to 8 Gbits
Customizable topology	up to 32 cavities per plant
Customizable RF input	up to 12 GHz
Maximum RF input power	20 dBm

## Hardware Interfaces



**1 Intel dual core COM Express with extensive communication interfaces:** The latest FPGAs and a powerful personal computer based on the PCIe interface offer good resources for the implementation of low-latency control algorithms, real-time data processing and dedicated RF system diagnostics tools.

**2 RF acquisition modules:** The system is configured to have four satellite modules, each of which can process up to 9 RF inputs. One channel on each board is used as RF reference signal for measurement and jitter cancellation purposes. Each RF acquisition module includes a built-in calibration system, temperature stabilization, jitter cancellation, LO distribution, partial vector sum computation and vector sum phase alignment functions.

**3 Vector modulator module:** Receives the partial vector sum signals from four satellite ADC modules through low-latency low-voltage differential signaling (LVDS) lines. The global vector sum is then processed by means of FPGA algorithms. The output of the control algorithms is then up-converted to the RF frequency and used as the transmitter drive signal.

**4 Timing module:** Generates a low jitter local oscillator (LO) signal and a suitable sampling clock for the down-conversion and acquisition processes. The designed acquisition structure enables a high level of amplitude and phase cavity field stabilization.

**5 Optional fast communication modules**

The Libera LLRF system architecture is based on PCIe implemented on AMC standards. It is a user-friendly network-attached device that has a powerful computational interconnect board (ICB) managing a number of satellite boards.

## Data Paths

Libera LLRF data paths. The powerful digital processing system, based on multiple FPGAs, implements the low latency cavity field control loop. Each stage of the processing chains is monitored. The raw samples are stored in large DDR2 RAM-based circular buffers or decimated in order to produce decimated streams for easier monitoring.

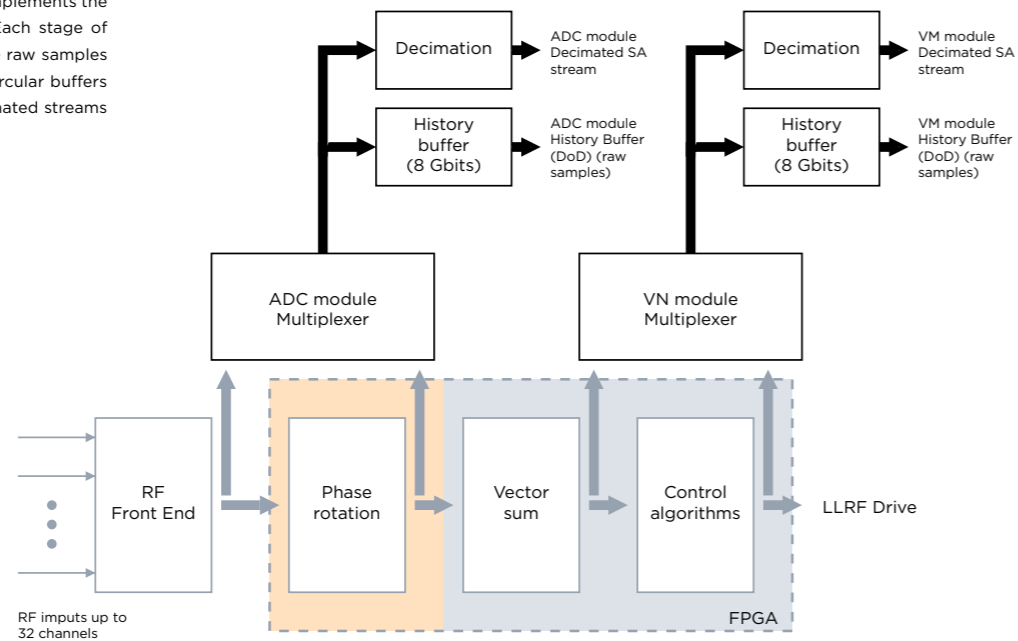

The powerful features of Libera LLRF enable RF system monitoring, configuration and diagnostics. The diagnostic algorithms automatically characterize the RF system transfer function by means of built-in vector network analysis. The RF parameters are then passed to a cavity field control loop stability analysis algorithm, which optimally configures the Libera LLRF parameters for closing a stable loop. Cavity decay analysis is then used in the case of pulsed applications to continuously monitor the cavity behavior for tuning and interlock purposes.

## Software Interfaces

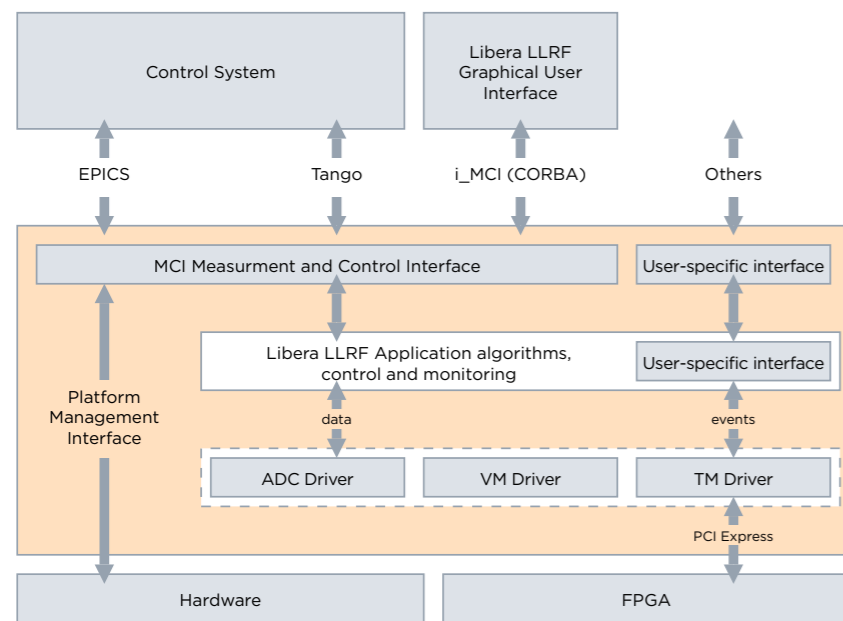

An important part of the LLRF application is implemented in software, running on a powerful COM Express computer, which is built into the Libera LLRF. Software layers are designed to make the use of the instrument easier. Software services turn the instrument into a network device with standard interfaces. The Libera LLRF provides a wealth of standard functionality and is also highly user-customizable.

## Graphical User Interface

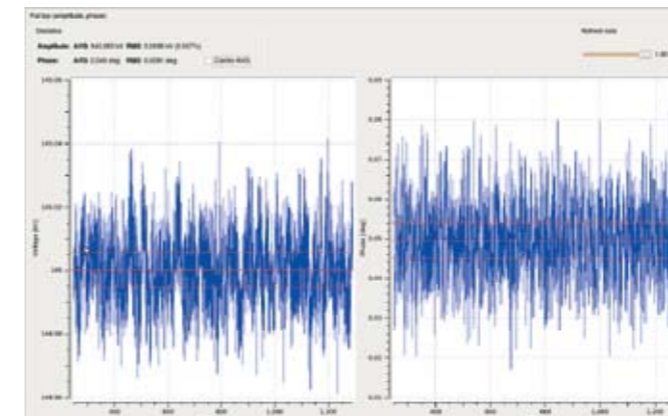

### Decimated signals

All the signals of the Libera LLRF system are also available in a decimated form for easy processing and display on control system screens. The cavity response to RF pulses is already available in the form of amplitude and phase signals.

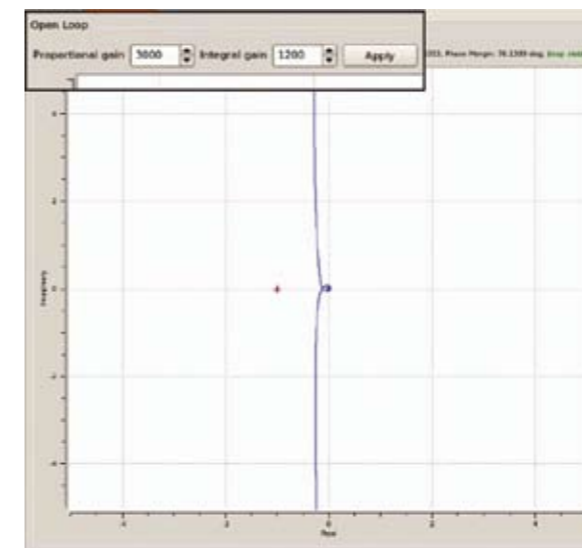

### RF system diagnostics

During operation, the cavity decay analysis and directional coupler signals are used to monitor and control the cavity tuning.



### Flat top analysis

The cavity voltage amplitude and phase stability can be easily measured to high resolution from the acquired samples. A long history of raw samples is available from the buffer. The effectiveness of the control algorithms in suppressing disturbances of the cavity field can be measured using this tool.

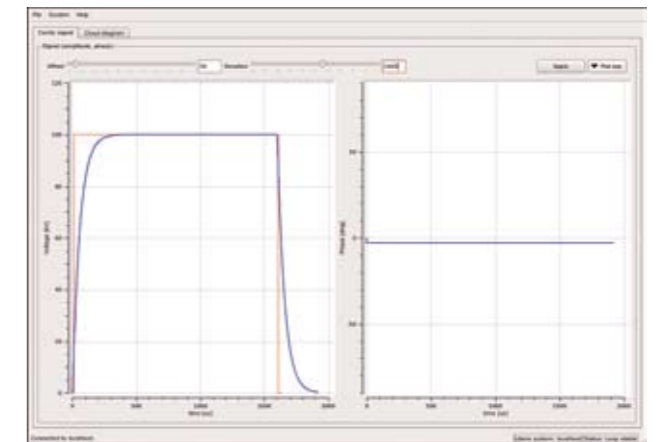

### Nyquist stability analysis

A powerful RF diagnostics system completely characterizes the RF system by means of built-in network vector analysis. Libera LLRF automatically uses diagnostic measurements to compute the optimal phase rotation for enabling a stable LLRF loop. The user is also provided with phase and gain stability margins. The open loop transfer function is displayed on a Nyquist diagram. The application suggests the optimum working parameters.

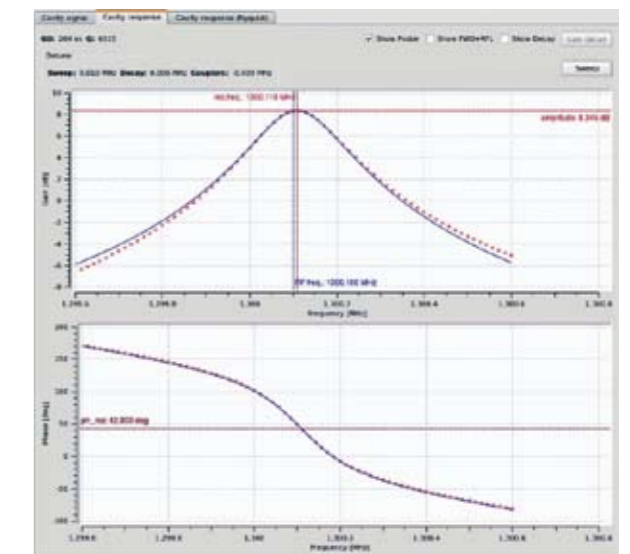

### System monitoring

The Libera LLRF system has an advanced health monitoring system that takes care of fans, currents, voltages and temperature.

# Related Products in the Accelerator System

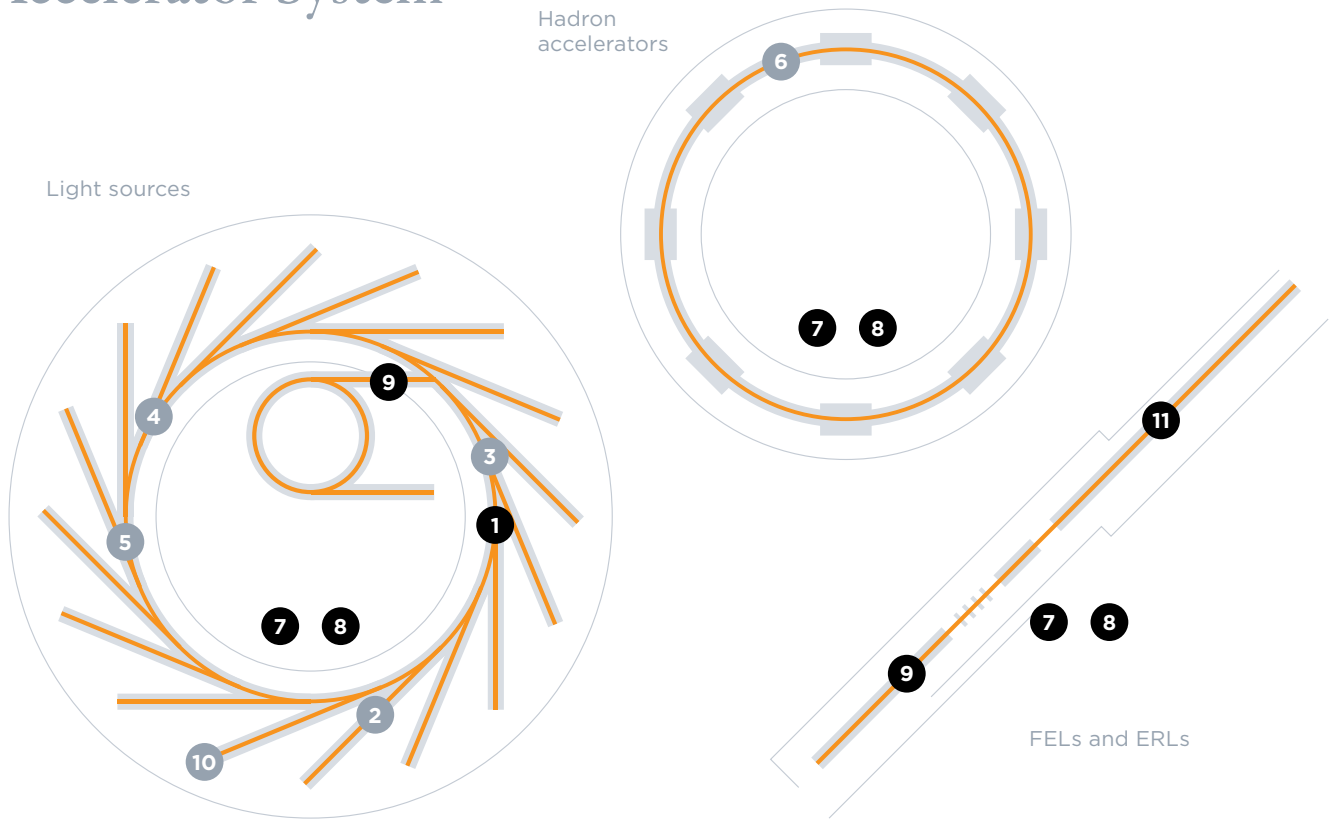

- 1 Libera Brilliance**  
*Electron beam position processor*
- 7 Libera LLRF**  
*Digital RF stabilization system*
- 8 Libera Sync**  
*Low-jitter clock distribution system*
- 9 Libera Brilliance Single Pass**  
*Electron beam position processor for single pass machines*
- 11 Libera Single Pass**  
*Single bunch position processor for cavity and stripline BPM pickups*
- +** *See the cover spread for the whole product range*

→ Solution	Building Block
Linac energy stabilization	Libera LLRF + Libera Sync + Libera Brilliance Single Pass (or Libera Single Pass)
Beam dump for injection efficiency studies	Libera Brilliance + Libera LLRF
Turn-by-turn beam studies	Libera Brilliance + Libera LLRF

## More at [www.i-tech.si](http://www.i-tech.si)

Visit our website to read more about Libera products, download conference papers on the use of Libera at different accelerators around the world, subscribe to the I-Tech Newsletter and learn about the next gathering of the community at the Libera Workshop.

## Technical Support

Prompt and reliable. You can ask for on-site support or we can assist you remotely. You are also welcome to join us at the Libera Workshop training sessions to get the most out of Libera products.



When your users demand stability.